



BETACRYL[®]
PURE ACRYLIC STONE

betaflex

betalite

**PRODUCT
CATALOGUE 5.0**

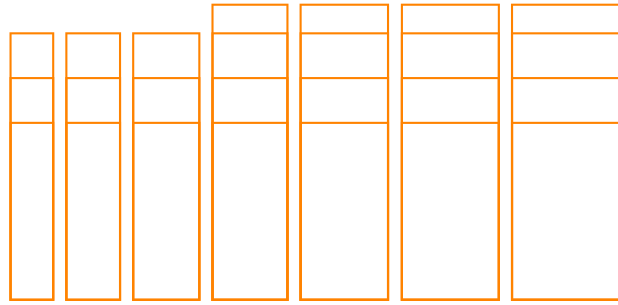

UNA FRONTIERA DIMENSIONALE D'ECCELLENZA



AN EXCELLENT RANGE OF DIMENSIONS
UNA GAMA DE TAMAÑOS DE EXCELENCIA
UNE GAMME DE TAILLES D'EXCELLENCE
EINE HERVORRAGENDE AUSWAHL AN GRÖSSEN

BETACRYL PURE ACRYLIC STONE

BETACRYL® Pure Acrylic Stone è un Solid Surface fabbricato per due terzi circa con idrossido di alluminio e per un terzo con resina acrilica e pigmenti coloranti naturali.

L'idrossido d'alluminio conferisce al prodotto un'ottima resistenza meccanica mentre la resina acrilica garantisce igienicità, idoneità al contatto con alimenti, impermeabilità e stabilità del colore nel tempo.

Nonostante la sua consistenza simile alla pietra è ripristinabile e di facile trasformazione con attrezzature per la lavorazione del legno. Può essere giuntato in maniera impercettibile e un semplice processo di termoformatura consente di realizzare superfici curve lasciando libero spazio alla fantasia dei progettisti.

BETACRYL® rispetta gli standard Euroclass B-s1-d0.

La nostra produzione, organizzata in modo rivoluzionario e unico, prevede la realizzazione di tutti i formati di lastra e tutti gli stampati nello stesso sito produttivo, attingendo dai medesimi serbatoi di materia prima, al fine di garantire costante uniformità di tinta da prodotto a prodotto.

BETACRYL® Pure Acrylic Stone is a Solid Surface material made of approximately two-thirds of aluminum hydroxide, a third of acrylic resin and natural pigments.

The aluminum hydroxide provides the product a particular strength, the quality of the acrylic resin ensures cleanliness, suitability for contact with food, water resistance and colour stability over time. Despite its consistency, similar to natural stone, BETACRYL® is restorable and can be fabricated with woodworking equipment.

It can be seamlessly joined and a simple thermoforming process allows to create curved surfaces allowing total freedom to the designers' imagination.

BETACRYL® complies with the Euroclass B-s1-d0 standards.

Our production system is designed in a so revolutionary and unique way that we can plan the manufacturing of sheets and shape products of any dimension within the same production site. By drawing from the same raw material storage tanks, we can also ensure colour uniformity from one product to another.

BETACRYL® Pure Acrylic Stone pertenece a la familia de las Superficies Solidas material compuesto de aproximadamente dos tercios de hidróxido de aluminio, de un tercio de resina de acrílico y de pigmentos naturales.

El hidróxido de aluminio dota el producto de una particular resistencia, las cualidades del acrílico le permite ser el material idóneo en contacto con alimentos, siendo impermeable, antibacteriano y su color estable en el tiempo. A pesar de su consistencia similar a piedras naturales, BETACRYL® es restaurable y puede ser transformado con las herramientas dedicadas a la madera.

BETACRYL® puede ser pegado con juntas imperceptible y un simple sistema de termo conformado permite fabricar curvas libres dejando una libertad a la imaginación de los diseñadores.

BETACRYL® es conforme a la normativa Euroclass B-s1-d0.

Nuestro sistema de producción es único! Se estructura de manera tan revolucionar que ofrece la posibilidad

que todos los paneles y productos moldeados, de cualquier tamaño, sean fabricados en el mismo lugar de producción utilizando una fuente común de materias primas. Esta característica única en el mercado nos permite garantizar la uniformidad del color de los productos de un baño a otro.

BETACRYL® Pure Acrylic Stone appartient à la famille des Solides Surfaces Acryliques. Il est constitué d'approximativement deux tiers d'hydroxyde d'aluminium, d'un tiers d'acrylique et de pigment naturel.

L'hydroxyde d'aluminium lui procure une grande résistance, la résine acrylique lui permet d'être la matière idéale au contact alimentaire car il est imperméable, antibactérien et sa couleur reste stable dans le temps.

Malgré sa composition proche des pierres naturelles, BETACRYL® est réparable, restaurable et transformable avec les outils du bois. BETACRYL® peut être collé créant des joints imperceptibles mais aussi être thermoformé grâce à un équipement standard de thermoformage pouvant créer des courbes et forme 3D laissant libre l'imagination des designers.

BETACRYL® est conforme à la norme Euroclass B-s1-d0.

Notre système de production est unique! Il est structuré de façon si révolutionnaire qu'il offre la possibilité de réaliser toutes les plaques et les produits moulés de n'importe quelle dimension sur le même site de production en utilisant une source commune de matières premières. Cette caractéristique unique sur le marché nous permet d'assurer l'uniformité de la couleur des produits d'un bain à l'autre.

BETACRYL® ist ein purer Acrylstein und ein solides Oberflächenmaterial, welches aus circa zwei Drittel Aluminiumhydroxid, einem Drittel Acrylharz und natürlichen Farbpigmenten hergestellt wird.

Das Aluminiumhydroxid verleiht dem Produkt eine ausgezeichnete mechanische Beständigkeit. Das Acrylharz gewährleistet Hygiene und somit auch die Nutzung mit Lebensmitteln, Wasserdichtigkeit und langanhaltende Stabilität der Farbe.

Trotz seiner Naturstein-ähnlichen Konsistenz, kann BETACRYL® durch Holzbearbeitungsmaschinen einfach erneuert und verändert werden. Das Material kann nahtlos zusammengefügt werden und ein Thermoverfahren erlaubt geschwungene Oberflächen zu gestalten, die der Fantasie des Designers keine Hindernisse stellen. BETACRYL® entspricht der Standard Euroklasse B-s1-d0.

Unser revolutionäres Produktionssystem ist so einzigartig strukturiert, dass es uns ermöglicht, am gleichen Produktionsstandort alle Formteile und Plattenmaße herzustellen. Beim Schöpfen aus den gleichen Rohstoffbehältern, können wir von einem Produkt auf das andere absolute Farbgleichheit garantieren.

NOVITÀ

NEWS

BETACRYL® Pure Acrylic Stone consolida la sua leadership di mercato arricchendo la propria gamma di lastre con due nuove larghezze esclusive: 610 e 1050mm. Ancora una volta BETACRYL® dimostra la massima attenzione per la varietà dei formati all'insegna della riduzione dei costi di trasformazione. Il crescente successo di Betaflex (la versione di BETACRYL® maggiormente termoformabile) ha stimolato l'ampliamento dei formati proposti con ben 11 referenze disponibili, distinte tra loro per larghezze e spessori. Nell'ambito delle tinte sono stati introdotti 3 nuovi decori marmorizzati in Betalite Modified Acrylic Stone, con venatura passante in tutto lo spessore, per realizzazioni di grande pregio.

I nostri designer hanno, inoltre, progettato una nuovissima linea di stampati, lavabi e vasche con bordi sottilissimi, che ricalca le più recenti tendenze stilistiche del mondo dell'arredo bagno. Nel catalogo vengono anche proposte esclusive novità in termini di macchine e accessori, sempre con l'obiettivo di agevolare le procedure di trasformazione dei nostri prodotti. Infine, per facilitare la progettazione di interni da parte di architetti e designer, sono adesso disponibili i file BIM di tutti i nostri prodotti, scaricabili direttamente dalla piattaforma internazionale bimobject.com.

BETACRYL® Pure Acrylic Stone consolidates its market leadership by enlarging its sheets range with two new exclusive widths: 610 and 1050mm. Once again BETACRYL pays close attention to the wide range of formats in order to reduce fabrication costs. The growing success of Betaflex (the most thermoformable version of BETACRYL®) stimulated the expansion of the suggested sizes with 11 available references, distinguished from each other by widths and thicknesses. Concerning colors, 3 new marbled decorations in Betalite Modified Acrylic Stone, with through-grain throughout the thickness, have been introduced for highly prestigious creations.

Following the latest trends in the bathroom furnishings domain our designers developed a brand new line of washbasins and bathtubs with very thin edges. For the first time BETACRYL® offers exclusive innovations in terms of machinery and accessories, always with the aim of simplifying fabrication processes. Last but not least, to facilitate interior design by architects and designers, the BIM files of all our products are now available, downloadable directly from the international bimobject.com platform.

BETACRYL® Pure Acrylic Stone consolida su liderazgo en el mercado al enriquecer su gama de planchas con dos nuevos anchos exclusivos: 610 y 1050 mm. Una vez más, BETACRYL® demuestra la máxima atención a la variedad de formatos para reducir los costos de producción. El creciente éxito de Betaflex (la versión más termoformable de BETACRYL®) ha estimulado la expansión de los formatos propuestos con hasta 11 referencias disponibles, distinguidas entre sí por anchos y espesores. Como parte de los colores, se han introducido 3 nuevas decoraciones de mármol en piedra acrílica modificada con betalite, con vetas en todo el grosor, para creaciones de gran prestigio.

Nuestros diseñadores también han diseñado una nueva línea de estampados, lavabos y bañeras con bordes muy finos, que sigue las últimas tendencias estilísticas en el mundo de los muebles de baño. El catálogo también ofrece novedades exclusivas en cuanto a máquinas y accesorios, siempre con el objetivo de facilitar los procesos de transformación de nuestros productos. Finalmente, para facilitar el diseño de interiores por arquitectos y diseñadores, los archivos BIM de todos nuestros productos ya están disponibles, descargables directamente desde la plataforma internacional bimobject.com.

BETACRYL® Pure Acrylic Stone consolide son leadership sur le marché en enrichissant sa gamme de plaques avec deux nouvelles largeurs exclusives: 610 et 1050 mm. BETACRYL® démontre une fois de plus la plus grande attention à la variété des formats ce qui réduit le coût de fabrication. Le succès grandissant de Betaflex (la version la plus thermoformable de BETACRYL®) a stimulé l'expansion des formats proposés avec pas moins de 11 références disponibles, se distinguant les unes des autres par des largeurs et des épaisseurs. Dans le cadre des couleurs, 3 nouvelles décorations marbrées en pierre acrylique modifiée Betalite, avec une veine traversante sur toute l'épaisseur, ont été introduites pour des créations très prestigieuses.

Nos designers ont également conçu une toute nouvelle gamme injectée, de lavabos et de baignoires aux bords très fins, qui suit les dernières tendances stylistiques du monde du mobilier de salle de bain. Le catalogue propose également des nouveautés exclusives en termes de machines et d'accessoires, toujours dans le but de faciliter les procédures de transformation de nos produits. Enfin, pour faciliter la décoration intérieure par les architectes et designers, les fichiers BIM de tous nos produits sont désormais disponibles, téléchargeables directement depuis la plateforme internationale bimobject.com.

BETACRYL® Pure Acrylic Stone fügt zwei neue exklusive Platten-Formate (610 und 1050 mm.) in seine schon vielfältige Produktpalette ein. Hiermit festigt BETACRYL Pure Acrylic Stone seine Position als Marktführender Anbieter und erweist erneut seine grosse Aufmerksamkeit für die Vielfalt der Formate, zur Optimierung der Verarbeitungskosten und Reduzierung der Materialkosten. Der wachsende Erfolg von Betaflex (das Produkt von BETACRYL® mit stäkster Thermoformbarkeit) hat die Erweiterung der angebotenen Formate auf nun 11 verschiedene Abmessungen angeregt, mit vielfältigen Breiten, Längen und Stärken. Für exklusive High-End Kreationen wurden unserer Farbenpalette 3 neue Marmordekors aus Betalite Modified Acrylic Stone hinzugefügt, mit Maserung durch die gesamte Stärke der Platten.

Unsere Designer haben auch eine brandneue Produkt-Linie von Waschbecken, Wannen und Zubehör mit extrem dünnen Kanten entworfen, die den neuesten Stilrends in der Welt der Badezimmereinrichtung folgt. Unser Katalog bietet auch exklusive Neuheiten in Bezug auf Verarbeitungs-Maschinen und Zubehör, immer mit dem Ziel, die Anwendung unserer Produkte zu erleichtern. Um die Planung und Gestaltung mit BETACRYL® Produkten für Architekten und Designer zu vereinfachen, sind die BIM-Dateien aller unserer Produkte verfügbar und können direkt von der internationalen Plattform bimobject.com heruntergeladen werden.

betaflex

EXTRA FLEXIBLE ACRYLIC STONE

Betaflex: il cuore BETACRYL® batte nella direzione della massima elasticità antibatterica.

Lo studio di nuove soluzioni e il costante sviluppo di BETACRYL® hanno condotto alla realizzazione di Betaflex, la nuovissima versione del nostro Pure Acrylic Stone.

Betaflex coniuga due primarie qualità del materiale: è totalmente antibatterico e garantisce una termoformabilità maggiore del 30%, lasciando inalterata la resistenza meccanica.

Un risultato unico per i prodotti della sua categoria.



Betaflex: the BETACRYL® heart beats in the maximum antibacterial elasticity direction.

The new solutions research and the constant development of BETACRYL® led to the creation of Betaflex, the brand new version of our Pure Acrylic Stone.

Betaflex combines two primary qualities of the material: it is totally antibacterial and guarantees a thermoformability extended of more than 30% compared to standard solid surface, leaving the mechanical resistance unchanged.

A unique and extraordinary result for the products in its category.

Betaflex: el corazón BETACRYL® late en la dirección de máxima elasticidad antibacteriana.

El estudio de nuevas soluciones y el desarrollo constante de BETACRYL® llevaron a la creación de Betaflex, la nueva versión de nuestra Piedra Acrílica Pura.

Betaflex combina dos cualidades principales del material: es totalmente antibacteriano y garantiza una termoformabilidad superior al 30%, sin cambios en la resistencia mecánica.

Un resultado único para los productos de su categoría.

Betaflex: le cœur BETACRYL® bat dans le sens d'une élasticité antibactérienne maximale

L'étude de nouvelles solutions et le développement constant de BETACRYL® ont conduit à la création de Betaflex, la toute nouvelle version de notre pierre acrylique pure.

Betaflex combine deux qualités principales du matériau: il est totalement antibactérien et garantit une thermoformabilité supérieure à 30%, laissant la résistance mécanique inchangée.

Un résultat unique pour les produits de sa catégorie.

Betaflex: Das BETACRYL®-Herz schlägt in Richtung maximaler antibakterieller Elastizität.

Die Suche nach neuen Lösungen und die stetige Weiterentwicklung von unserem Spitzenprodukt BETACRYL® führten zur Entwicklung von Betaflex, die brandneue Version unseres reinen Acrylsteins (Pure Acrylic Stone).

Betaflex kombiniert die zwei Hauptmerkmale dieses Materials: Es ist vollständig antibakteriell und ermöglicht eine Thermoformbarkeit von über 30%, bei unveränderter mechanischer Beständigkeit.

Ein einzigartiges Resultat für Produkte in dieser Kategorie.



Betaflex può essere utilizzato come tradizionale Solid Surface in architettura e product design, ma esalta le sue specifiche qualità per tutte le realizzazioni curve: in ambito sanitario-medicale, in ambienti di laboratorio e per ogni installazione dove siano richieste massima duttilità ed igiene.

I raggi di curvatura possibili con Betaflex (12mm) possono essere inferiori a 10mm (raggio interno) e la sua capacità di estensione è doppia.

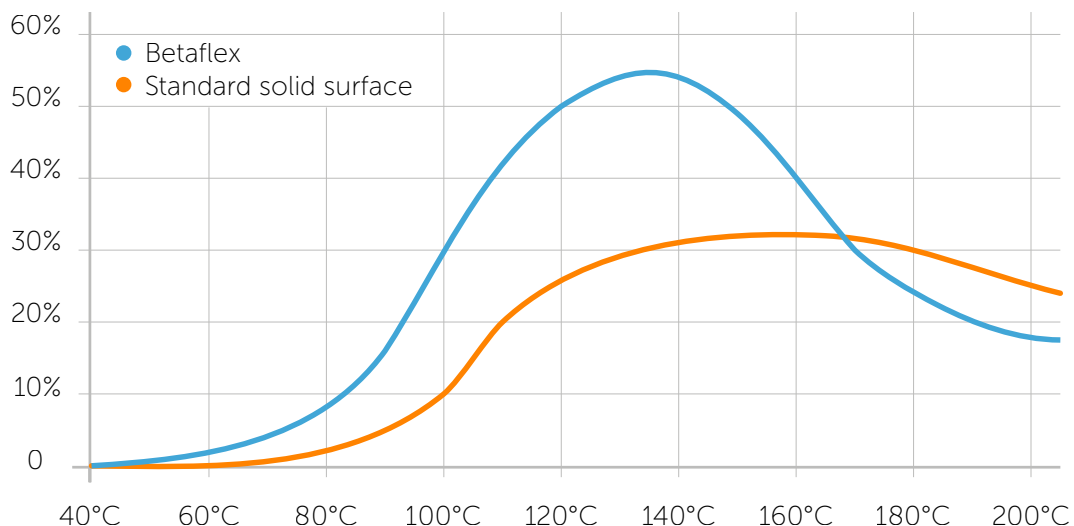

Betaflex can be used as a traditional Solid Surface in architecture and industrial design, but enhances its specific qualities for all curved creations: in the healthcare-medical field, in laboratory environments and for any installation where maximum ductility and hygiene are required. The radius of the thermoforming possible bends with 12mm Betaflex can be less than 10mm (internal radius) and its extension capacity of this new version is double than standard.

Betaflex se puede usar como una superficie sólida tradicional en arquitectura y diseño de productos, pero mejora sus cualidades específicas para todas las creaciones curvas: en el campo de la salud, en entornos de laboratorio y para cualquier instalación donde se requiera la máxima ductilidad e higiene. Los radios de curvatura posibles con Betaflex de 12mm pueden ser inferiores a 10 mm (radio interno) y su capacidad de extensión es doblada.

Betaflex peut être utilisé comme surface solide traditionnelle dans l'architecture et la conception de produits, mais améliore ses qualités spécifiques pour toutes les créations courbes: dans le domaine médical, dans les environnements de laboratoire et pour toute installation où une ductilité et une hygiène maximales sont requises. Les rayons de courbure possibles avec Betaflex de 12mm peuvent être inférieurs à 10 mm (rayon interne) et sa capacité d'extension est doublé.

Betaflex kann als traditionelle Solid Surface in Architektur und Produktdesign verwendet werden, doch kommen seine spezifischen Eigenschaften vor allem bei Formteilen zur vollen Geltung: im medizinischen Bereich, in Laborumgebungen und für jede Anwendung, bei der maximale Formbarkeit und Hygiene erforderlich sind. Die mit 12mm Betaflex möglichen Krümmungsradien können weniger als 10 mm Innenradius betragen, bei doppelter Dehnungskapazität.

Betaflex consente la realizzazione di top con lavabi da bagno molto più profondi, con raggi incredibilmente ridotti e pareti verticali, contribuendo ad una riduzione di costi di trasformazione fino a ieri impossibile.

Rimangono invariate le consuete qualità del materiale: la totale stabilità cromatica, gli incollaggi con giunte impercettibili, la durabilità nel tempo e l'aspetto setoso.



Betaflex allows the fabrication of tops with much deeper washbasins, with incredibly reduced corner radius and pretty vertical walls, contributing to a labor costs reduction previously impossible. The usual qualities of the material remain unchanged: total chromatic stability, imperceptible joints, durability and silky appearance.

Betaflex permite la creación de encimeras con lavabos mucho más profundos, con radios increíblemente reducidos y paredes verticales, lo que contribuye a una reducción en los costos de transformación y a la vez alcanzar resultados que antes eran imposible. Las cualidades habituales del material permanecen sin cambios: estabilidad cromática total, pegado con juntas imperceptibles, durabilidad en el tiempo y aspecto sedoso.

Betaflex permet la création de plans avec des lavabos beaucoup plus profonds, avec des rayons et des parois verticales incroyablement réduits, contribuant à une réduction des coûts de transformation auparavant impossible. Les qualités habituelles du matériau restent inchangées: stabilité chromatique totale, collage avec des joints imperceptibles, durabilité dans le temps et aspect soyeux.

Betaflex ermöglicht die Herstellung von Oberflächen mit viel tieferen Becken, mit unglaublich reduzierten Radien und vertikalen Wänden, was zu einer bisher unvorstellbaren Reduzierung der Produktionskosten beiträgt. Die üblichen Materialeigenschaften bleiben unverändert: totale Farbbeständigkeit, fugenlose Verarbeitung, Haltbarkeit über die Zeit und seidiges Aussehen.



| cod. | | color | mm | m ² | | pallet |
|------------------|----------|---------------|-------------------|----------------|------------|--------|
| 12.366.76/8-100 | betaflex | Classic White | 12 x 3660 x 760 | 2,78 | | 15 un. |
| 9.366.93/8-100 | betaflex | Classic White | 9 x 3660 x 930 | 3,40 | NEW | 20 un. |
| 9.244.105/8-100 | betaflex | Classic White | 9 x 2440 x 1050 | 2,56 | NEW | 15 un. |
| 9.305.105/8-100 | betaflex | Classic White | 9 x 3050 x 1050 | 3,20 | NEW | 15 un. |
| 9.366.105/8-100 | betaflex | Classic White | 9 x 3660 x 1050 | 3,84 | NEW | 15 un. |
| 12.305.105/8-100 | betaflex | Classic White | 12 x 3050 x 1050 | 3,20 | NEW | 12 un. |
| 12.366.122/8-100 | betaflex | Classic White | 12 x 3660 x 1220 | 4,47 | NEW | 12 un. |
| 3.305.135/8-100 | betaflex | Classic White | 3,5 x 3050 x 1350 | 4,12 | NEW | 50 un. |
| 6.366.135/8-100 | betaflex | Classic White | 6 x 3660 x 1350 | 4,94 | | 20 un. |
| 9.366.135/8-100 | betaflex | Classic White | 9 x 3660 x 1350 | 4,94 | | 15 un. |
| 12.366.135/8-100 | betaflex | Classic White | 12 x 3660 x 1350 | 4,94 | | 12 un. |

betalite

MODIFIED ACRYLIC SURFACE

| cod. | | color | mm | m ² | pallet |
|------------------|----------|-------------|------------------|----------------|--------|
| 12.366.76/9-010 | betalite | Artic White | 12 x 3660 x 760 | 2,78 | 15 un. |
| 12.366.135/9-010 | betalite | Artic White | 12 x 3660 x 1350 | 4,94 | 12 un. |

A completare la nostra prestigiosa gamma di prodotti, nasce Betalite, un Modified Acrylic Solid Surface di ultima generazione, che compensa la sua ridotta termoformabilità con un prezzo particolarmente accattivante e una accresciuta stabilità di tinta nel tempo.





Intended to integrate our remarkable range of products, Betalite represents our most innovative and updated Modified Acrylic Solid Surface item. Its relatively reduced thermoformability is offset by its particularly attractive and affordable price and increased colour stability over time.

Para completar nuestra prestigiosa gama de productos, le presentamos el Betalite, un nuevo modelo de Modified Acrylic Solid surfaces innovador y de última generación. Este material compensa su reducida termoconformabilidad, con precios muy ventajosos y competitivos y con su mantenido de color a lo largo del tiempo.

Afin de compléter notre prestigieuse gamme de produits, nous vous présentons le Betalite, un nouveau modèle de Solid Surface Acrylique Modifiée très innovant et de la dernière génération qui compense ses limites en thermoformabilité, par des prix très avantageux et compétitifs et une stabilité de sa couleur au fil du temps.

Um unsere bemerkenswerte Auswahl an Produkten zu integrieren, entsteht Betalite, eine modified solid Surface, welche ihre reduzierte thermische Formbarkeit durch einen besonders attraktiven und erschwinglichen Preis und durch eine gute Farbstabilität im Laufe der Zeit kompensiert.

DIMENSIONI E SPESSORI



DIMENSIONS
DIMENSIONES Y ESPESORES
DIMENSIONS ET ÉPAISSEURS
MAßE UND STÄRKEN

La flessibilità produttiva dei nostri impianti permette di produrre lastre in Pietra Acrilica BETACRYL®, Betaflex e Betalite in spessori compresi tra 3.5mm e 25mm, larghezze fino a 1520mm e lunghezze fino a 4050mm.

The production flexibility of our plants allows to manufacture our BETACRYL® Pure Acrylic Stone, Betaflex and Betalite sheets in thicknesses ranging from 3.5mm and 25mm, widths up to 1520mm and lengths up to 4050mm.

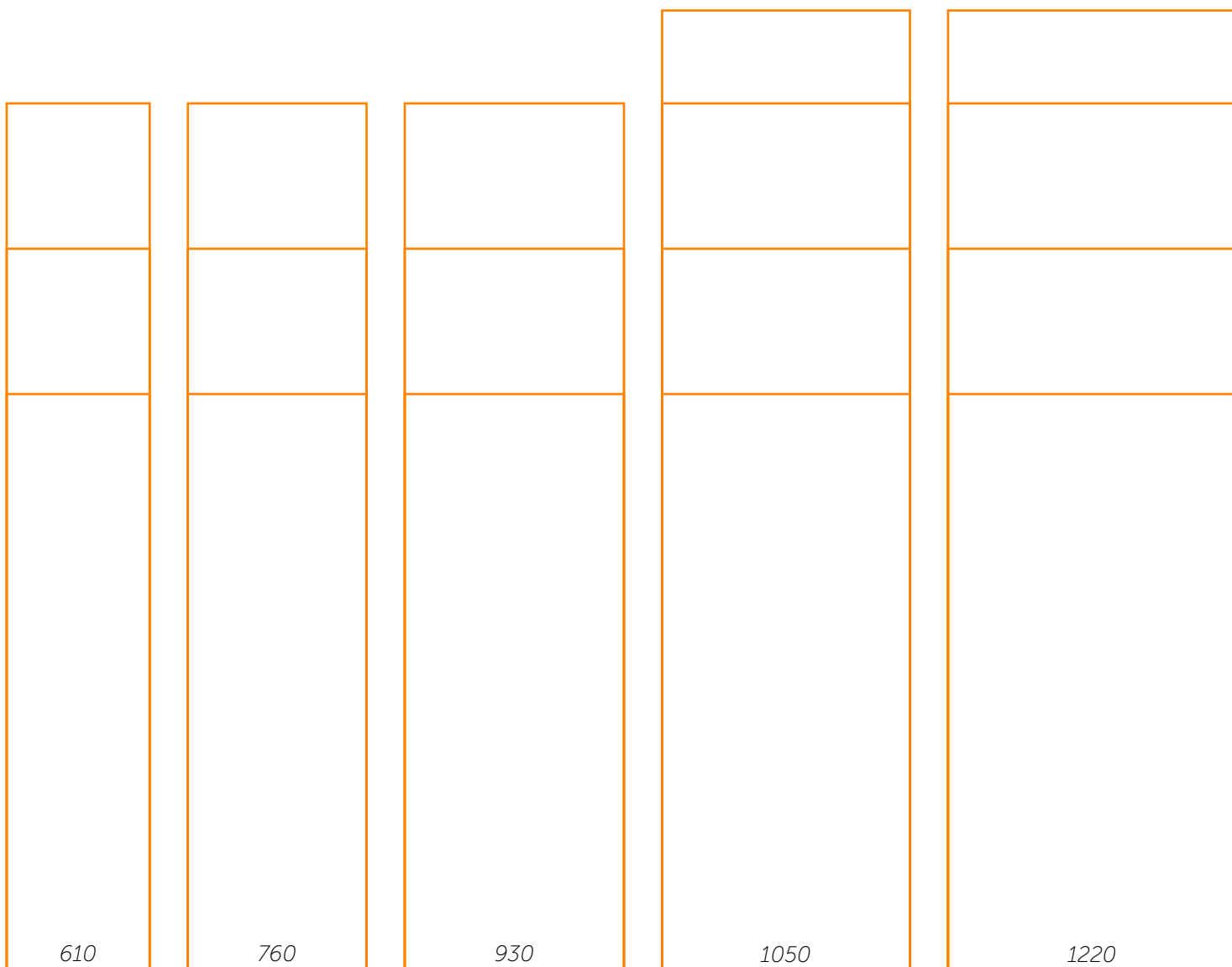



La flexibilidad de nuestras instalaciones de producción permite fabricar paneles de piedra acrílica BETACRYL®, Betaflex y Betalite de espesores entre 3,5 mm y 25 mm, de anchura hasta 1.520 mm y de longitud hasta 4050mm.

La flexibilité de notre usine de production nous permet de fabriquer des panneaux en pierre acrylique BETACRYL®, Betaflex et Betalite dans des épaisseurs comprises entre 3,5 mm et 25 mm, des largeurs jusqu'à 1520 mm et des longueurs jusqu'à 4050mm.

Die Produktions-Flexibilität unserer Systeme ermöglicht es uns, Platten aus dem Acrylstein BETACRYL®, Betaflex und Betalite in einer Stärke zwischen 3,5 mm und 25 mm, einer Breite bis zu 1520 mm und einer Länge bis zu 4050mm herzustellen.

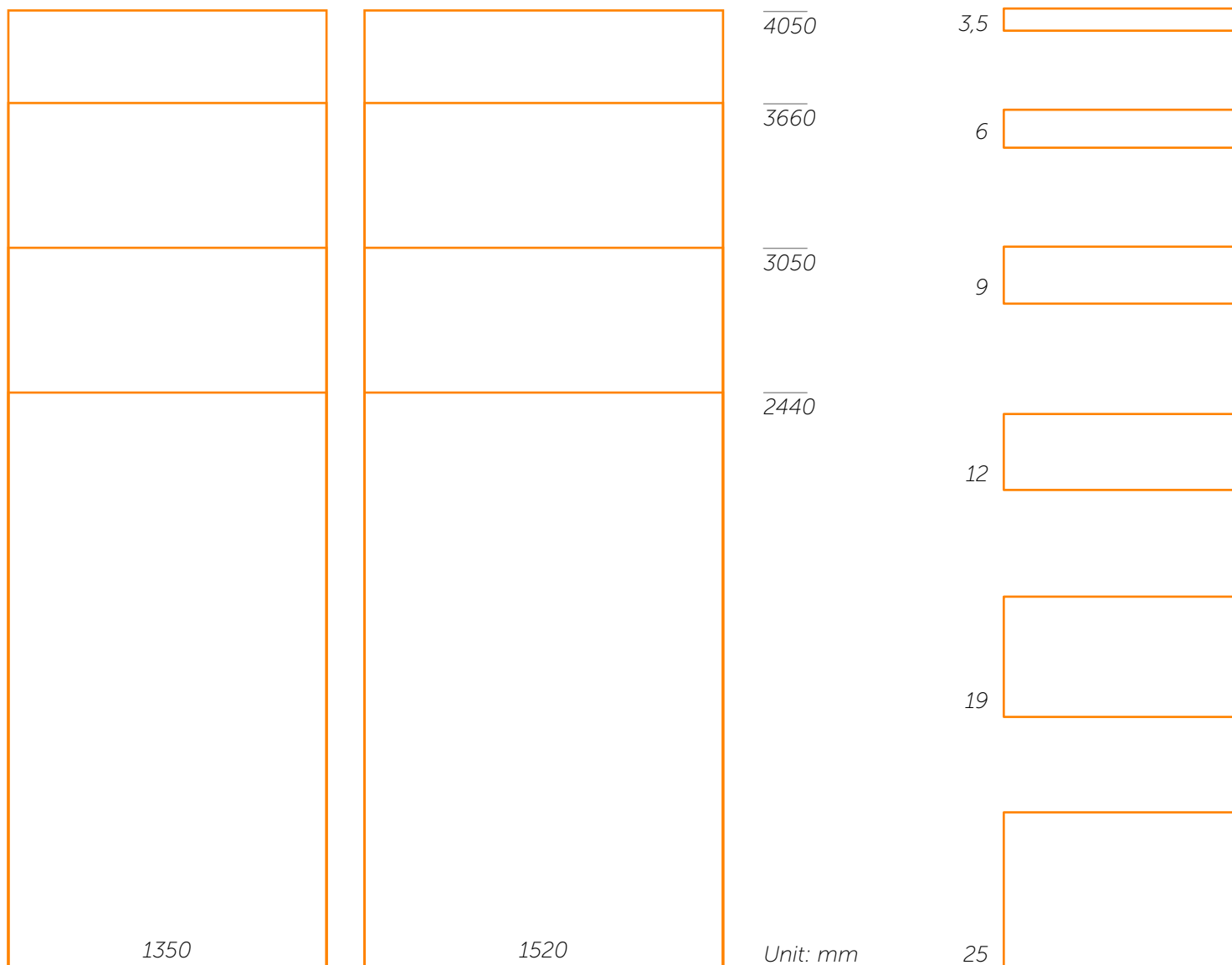

LASTRE IN STOCK

SHEETS AVAILABLE IN STOCK
 PLACAS DISPONIBLES EN STOCK
 PLAQUES DISPONIBLES EN STOCK
 AUF LAGER VERFÜGBARE PLATTEN

| 3,5 mm | | | | 6 mm | | | |
|--------|------|------|------|------|------|------|------|
| | 2440 | 3050 | 3660 | | 2440 | 3050 | 3660 |
| 610 | | | | 610 | | | |
| 760 | | ● | | 760 | ● | | ● |
| 930 | ● | ● | | 930 | ● | | ● C |
| 1050 | | | | 1050 | | | |
| 1220 | ● | | | 1220 | ● | ● | |
| 1350 | ● | ● | | 1350 | | ● | ● ● |
| 1520 | | | | 1520 | | | |

| 9 mm | | | | 12 mm | | | |
|------|------|------|------|-------|------|------|---------|
| | 2440 | 3050 | 3660 | | 2440 | 3050 | 3660 |
| 610 | ● | ● | ● | 610 | | ● | ● |
| 760 | | | ● | 760 | | ● | ● ● ● C |
| 930 | | ● | ● ● | 930 | | ● | ● C V |
| 1050 | ● | ● | ● | 1050 | | ● | |
| 1220 | | ● | ● | 1220 | | ● | ● ● |
| 1350 | | ● | ● ● | 1350 | | ● | ● ● ● |
| 1520 | | | | 1520 | | ● V | ● |

| 19 mm | | | | 25 mm | | | |
|-------|------|------|------|-------|------|------|------|
| | 2440 | 3050 | 3660 | | 2440 | 3050 | 3660 |
| 610 | | | ● | 610 | | | |
| 760 | | ● | ● | 760 | | | |
| 930 | | ● | | 930 | ● | | |
| 1050 | | | | 1050 | | | |
| 1220 | ● | | | 1220 | | | |
| 1350 | | | | 1350 | | | |
| 1520 | | | | 1520 | | | |

- Betacryl 0-100 Classic White
- Betalite 9-010 Artic White
- Betaflex 8-100 Classic White

C Colors

V Venus

V Venus

DIMENSIONI PERSONALIZZATE

CUSTOM SIZES

DIMENSIONES PERSONALIZADAS

DIMENSIONS PERSONNALISÉES

SONDERANFERTIGUNGEN

L'ampia flessibilità del nostro innovativo sistema produttivo permette di produrre lastre in Pietra Acrilica BETACRYL® in spessori compresi tra 3,5mm e 25mm, larghezze comprese tra 610mm e 1520mm e lunghezze fino a 4050mm. Al fine di mantenere invariati i nostri elevati standard di qualità anche per lotti di produzione custom, sono previsti lotti minimi, che variano a seconda degli spessori e delle misure richieste. Tempi di consegna per dimensioni speciali: 8 – 10 settimane.

Le produzioni personalizzate, in termini di misure e spessori, sono soggette a specifiche quotazioni.

ESEMPI | EXAMPLES | EJEMPLOS | EXEMPLES | BEISPIELE

| mm | min. un. |
|-------------------------|----------|
| 16 x 3050 x 1220 | 50 un. |
| 12 x 2090 x 1350 | 80 un. |

The wide flexibility of our innovative production system enables to manufacture our BETACRYL® Pure Acrylic Stone sheets in thicknesses ranging from 3.5 to 25mm, widths ranging from 610 to 1520mm and lengths up to 4050mm. In order to keep unchanged our high quality production standards even for custom productions, we need to require minimum order quantities, which may vary according to the requested thicknesses and dimension. For special dimension productions we estimate a delivery time of around 8-10 weeks. Our custom productions, in terms of sizes and thicknesses, are subject to specific price quotations.

La gran flexibilidad de nuestro innovador sistema de producción permite fabricar paneles de piedra acrílica BETACRYL® de espesores que van desde 3,5 hasta 25 mm, anchura de 610 a 1520mm y longitudes hasta 4050mm. Para producciones de encargo y con el fin de mantener nuestros altos estándares de calidad, se solicita cantidades mínimas de pedido. Estos pueden variar según el espesor y tamaño de los paneles. Nuestras planchas de tamaño personalizados están sujetas a precios especiales y requieren alrededor de 8 a 10 semanas de entrega.

La grande flexibilité de notre système de production innovant nous permet de fabriquer des plaques en pierre acrylique BETACRYL® dans des épaisseurs comprises entre 3,5 et 25 mm, largeurs entre 610 et 1520mm et longueurs jusqu' à 4050mm. Pour les productions personnalisées et dans le souci de maintenir nos standards de qualité élevés, des quantités minimales de commande sont demandées. Elles peuvent varier selon l'épaisseur et la taille des plaques. Nos productions de plaques de dimensions personnalisées sont soumises à prix spéciaux et requièrent des délais de livraison d'environ 8 à 10 semaines.

Die große Flexibilität unseres innovativen Produktionssystems ermöglicht es uns, eine breite Auswahl an Plattenstärken und -maßen anbieten zu können. Unsere Platten aus BETACRYL® reinem Acrylstein können Stärken von 3,5 bis 25mm, Breiten von 610 bis zu 1520mm und Längen bis zu 4050mm aufweisen. Um unsere hohen Qualitätsstandards auch bei Sonderanfertigungen unverändert beibehalten zu halten, sind Mindestbestellmengen, die je nach den verlangten Plattenstärken und -maßen variieren können, erforderlich. Sonderanfertigungen benötigen eine Lieferzeit zwischen 8 und 10 Wochen. Unsere maßgefertigten Produktionen, im Hinblick auf die Maße und die Stärken, unterliegen spezifischen Preisen.

COLORI

COLOURS
COLORES
COULEURS
FARBEN

| | | | |
|---|---|---|--|
|  0 - 100 Classic White | <i>betaflex</i>  8 - 100 Classic White | betalite  9 - 010 Artic White |  0 - 011 Alpi White |
|   0 - 090 Igloo White |  0 - 110 Vanilla Ice |  0 - 140 Butter |  0 - 130 Traditional Bone |
|  0 - 101 Old Cameo |  0 - 810 Cloud Grey |   0 - 840 Smart Grey | NEW  0 - 830 Clay Grey |
|   0 - 850 Concrete Grey |   0 - 710 Terra Brown |   0 - 700 Coffee Brown |   0 - 999 Night Dark |



Le tonalità più scure non sono consigliate per applicazioni che prevedono l'uso intensivo della superficie.

The darkest colour shades are not recommended for applications involving a heavy-duty use of the surface.

Los colores oscuros no se recomiendan para aplicaciones que requieren un uso intenso de la superficie sólida.

Les nuances de couleur foncées ne sont pas recommandées pour des applications qui impliquent l'utilisation intensive de la surface.

Eine Anwendung der dunkelsten Farbtöne wird bei Oberflächen, welche sich durch intensive Nutzung hervorheben, nicht empfohlen.



Traslucente | Translucent | Translúcido | Translucide | Transluzent

COLORI VENATI

VEINED COLOURS
COLORES VETEADOS
COULEURS MARBRÉES
MARMORIERTE FARBEN

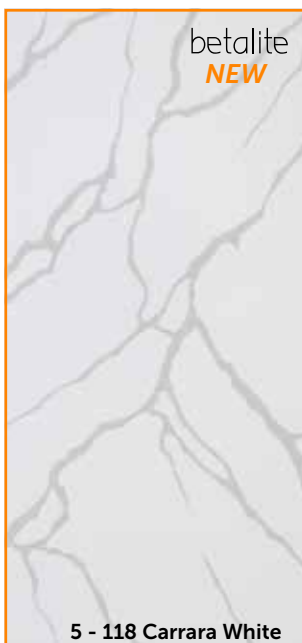

Le venature passanti potrebbero non garantire la continuità del disegno in caso di giunture.

The through veins may not guarantee the continuity of the design in case of joints.

Las venas pasantes pueden no garantizar la continuidad del diseño en caso de juntas.

Les veines traversantes peuvent ne pas garantir la continuité de la conception en cas de joints.

Die durchgehenden Venen garantieren möglicherweise nicht die Kontinuität der Konstruktion bei Gelenken.



LASTRE CLASSIC WHITE

CLASSIC WHITE SHEETS
PLANCHAS CLASSIC WHITE
PLAQUES EN CLASSIC WHITE
CLASSIC WHITE PLATTEN

CLASSIC WHITE

610

| cod. | | color | mm | m ² | | pallet |
|-----------------|----------|---------------|-----------------|----------------|------------|--------|
| 9.244.61/0-100 | BETACRYL | Classic White | 9 x 2440 x 610 | 1,49 | NEW | 20 un. |
| 9.305.61/0-100 | BETACRYL | Classic White | 9 x 3050 x 610 | 1,86 | NEW | 20 un. |
| 9.366.61/0-100 | BETACRYL | Classic White | 9 x 3660 x 610 | 2,23 | NEW | 20 un. |
| 12.305.61/0-100 | BETACRYL | Classic White | 12 x 3050 x 610 | 1,86 | NEW | 15 un. |
| 12.366.61/0-100 | BETACRYL | Classic White | 12 x 3660 x 610 | 2,23 | NEW | 15 un. |
| 19.366.61/0-100 | BETACRYL | Classic White | 19 x 3660 x 610 | 2,23 | NEW | 12 un. |

CLASSIC WHITE

760

| cod. | | color | mm | m ² | pallet |
|-----------------|----------|---------------|------------------|----------------|--------|
| 3.305.76/0-100 | BETACRYL | Classic White | 3,5 x 3050 x 760 | 2,32 | 50 un. |
| 6.244.76/0-100 | BETACRYL | Classic White | 6 x 2440 x 760 | 1,85 | 30 un. |
| 6.366.76/0-100 | BETACRYL | Classic White | 6 x 3660 x 760 | 2,78 | 30 un. |
| 9.366.76/0-100 | BETACRYL | Classic White | 9 x 3660 x 760 | 2,78 | 20 un. |
| 12.305.76/0-100 | BETACRYL | Classic White | 12 x 3050 x 760 | 2,32 | 15 un. |
| 12.366.76/0-100 | BETACRYL | Classic White | 12 x 3660 x 760 | 2,78 | 15 un. |
| 12.366.76/8-100 | betaflex | Classic White | 12 x 3660 x 760 | 2,78 | 15 un. |
| 12.366.76/9-010 | betalite | Artic White | 12 x 3660 x 760 | 2,78 | 15 un. |
| 19.305.76/0-100 | BETACRYL | Classic White | 19 x 3050 x 760 | 2,32 | 12 un. |
| 19.366.76/0-100 | BETACRYL | Classic White | 19 x 3660 x 760 | 2,78 | 12 un. |

CLASSIC WHITE

930

| cod. | | color | mm | m ² | | pallet |
|-----------------|----------|---------------|------------------|----------------|------------|---------|
| 3.244.93/0-100 | BETACRYL | Classic White | 3,5 x 2440 x 930 | 2,27 | | 50 un. |
| 3.305.93/0-100 | BETACRYL | Classic White | 3,5 x 3050 x 930 | 2,84 | | 50 un. |
| 6.244.93/0-100 | BETACRYL | Classic White | 6 x 2440 x 930 | 2,27 | | 30 un. |
| 6.366.93/0-100 | BETACRYL | Classic White | 6 x 3660 x 930 | 3,40 | | 30 un. |
| 9.305.93/0-100 | BETACRYL | Classic White | 9 x 3050 x 930 | 2,84 | NEW | 20.un. |
| 9.366.93/0-100 | BETACRYL | Classic White | 9 x 3660 x 930 | 3,40 | | 20 un. |
| 9.366.93/8-100 | betaflex | Classic White | 9 x 3660 x 930 | 3,40 | NEW | 20 un. |
| 12.305.93/0-100 | BETACRYL | Classic White | 12 x 3050 x 930 | 2,84 | | 15 un. |
| 12.366.93/0-100 | BETACRYL | Classic White | 12 x 3660 x 930 | 3,40 | | 15 un. |
| 19.305.93/0-100 | BETACRYL | Classic White | 19 x 3050 x 930 | 2,84 | | 12 un. |
| 25.244.93/0-100 | BETACRYL | Classic White | 25 x 2440 x 930 | 2,27 | | 12 un.. |

CLASSIC WHITE

1050

| cod. | | color | mm | m ² | | pallet |
|------------------|--------------------------|---------------|------------------|----------------|------------|--------|
| 9.244.105/8-100 | betaflex | Classic White | 9 x 2440 x 1050 | 2,56 | NEW | 15 un. |
| 9.305.105/8-100 | betaflex | Classic White | 9 x 3050 x 1050 | 3,20 | NEW | 15 un. |
| 9.366.105/8-100 | betaflex | Classic White | 9 x 3660 x 1050 | 3,84 | NEW | 15 un. |
| 12.305.105/8-100 | betaflex | Classic White | 12 x 3050 x 1050 | 3,20 | NEW | 12 un. |

CLASSIC WHITE

1220

| cod. | | color | mm | m ² | | pallet |
|------------------|----------|---------------|-------------------|----------------|------------|--------|
| 3.244.122/0-100 | BETACRYL | Classic White | 3,5 x 2440 x 1220 | 2,98 | | 50 un. |
| 6.244.122/0-100 | BETACRYL | Classic White | 6 x 2440 x 1220 | 2,98 | | 30 un. |
| 6.305.122/0-100 | BETACRYL | Classic White | 6 x 3050 x 1220 | 3,72 | | 30 un. |
| 9.305.122/0-100 | BETACRYL | Classic White | 9 x 3050 x 1220 | 3,72 | | 15 un. |
| 9.366.122/0-100 | BETACRYL | Classic White | 9 x 3660 x 1220 | 4,47 | | 15 un. |
| 12.305.122/0-100 | BETACRYL | Classic White | 12 x 3050 x 1220 | 3,72 | | 12 un. |
| 12.366.122/0-100 | BETACRYL | Classic White | 12 x 3660 x 1220 | 4,47 | | 12 un. |
| 12.366.122/8-100 | betaflex | Classic White | 12 x 3660 x 1220 | 4,47 | NEW | 12 un. |
| 19.244.122/0-100 | BETACRYL | Classic White | 19 x 2440 x 1220 | 2,98 | | 10 un. |

CLASSIC WHITE

1350

| cod. | | color | mm | m ² | | pallet |
|------------------|----------|---------------|-------------------|----------------|------------|--------|
| 3.244.135/0-100 | BETACRYL | Classic White | 3,5 x 2440 x 1350 | 3,29 | | 50 un. |
| 3.305.135/8-100 | betaflex | Classic White | 3,5 x 3050 x 1350 | 4,12 | NEW | 50 un. |
| 6.305.135/0-100 | BETACRYL | Classic White | 6 x 3050 x 1350 | 4,12 | | 20 un. |
| 6.366.135/0-100 | BETACRYL | Classic White | 6 x 3660 x 1350 | 4,94 | | 20 un. |
| 6.366.135/8-100 | betaflex | Classic White | 6 x 3660 x 1350 | 4,94 | | 20 un. |
| 9.305.135/0-100 | BETACRYL | Classic White | 9 x 3050 x 1350 | 4,12 | | 15 un. |
| 9.366.135/0-100 | BETACRYL | Classic White | 9 x 3660 x 1350 | 4,94 | | 15 un. |
| 9.366.135/8-100 | betaflex | Classic White | 9 x 3660 x 1350 | 4,94 | | 15 un. |
| 12.305.135/0-100 | BETACRYL | Classic White | 12 x 3050 x 1350 | 4,12 | | 12 un. |
| 12.366.135/0-100 | BETACRYL | Classic White | 12 x 3660 x 1350 | 4,94 | | 12 un. |
| 12.366.135/8-100 | betaflex | Classic White | 12 x 3660 x 1350 | 4,94 | | 12 un. |
| 12.366.135/9-010 | betalite | Artic White | 12 x 3660 x 1350 | 4,94 | | 12 un. |

CLASSIC WHITE

1520

| cod. | | color | mm | m ² | pallet |
|------------------|----------|---------------|------------------|----------------|--------|
| 12.305.152/0-100 | BETACRYL | Classic White | 12 x 3050 x 1520 | 4,64 | 10 un. |
| 12.366.152/0-100 | BETACRYL | Classic White | 12 x 3660 x 1520 | 5,56 | 10 un. |

LASTRE COLORATE

COLORED SHEETS
PLACAS COLORADA
PLAQUES COLORÉES
FARBIGE PLATTEN

COLORI PERSONALIZZATI

CUSTOM COLOURS
COLORES PERSONALIZADOS
COULEURS PERSONNALISÉES
SONDERFARBEN

Come per le dimensioni lastra, anche per i colori è possibile realizzare dei copy colour a richiesta.

Il lotto minimo di produzione per nuovi colori varia secondo i formati richiesti.

Tempi di consegna per colori speciali: 8 – 10 settimane dall'approvazione del campione di produzione.

Le produzioni di colori personalizzati sono soggette a specifiche quotazioni.

ESEMPI | EXAMPLES | EJEMPLOS | EXEMPLES | BEISPIELE

| mm | min. un. |
|------------------|----------|
| 6 x 2440 x 1220 | 160 un. |
| 12 x 3660 x 1350 | 50 un. |
| 19 x 3050 x 930 | 50 un. |

We are able to customise sheets not only in their dimensions but also in their colour. On request we can manufacture sheets in any colour you wish. The minimum order quantity for custom colour productions may vary according to the requested dimensions. For special colour productions we estimate a delivery time of around 8-10 weeks after the colour sample is approved.

Our custom colour productions are subject to specific price quotations.

Es posible realizar no solo cualquier panel de dimensión personalizada pero también cualquier tono de color. Usted puede incluso crear sus propios colores personalizados y, a petición, vamos a producirlas. Las cantidades mínimas requeridas pueden variar dependiendo del tamaño de los paneles. Nuestros productos de colores personalizados están sujetos a precios especiales y requieren de entrega alrededor de 8 a 10 semanas a partir de la aprobación de la muestra de color.

Il est possible de réaliser les plaques, non seulement de n'importe quelle dimension mais également de n'importe quelle nuance de couleur. Vous pouvez même créer vos propres couleurs personnalisées et, sur demande, nous les produirons. Les quantités minimales de commande requises peuvent varier selon la taille des plaques demandées. Nos productions de couleurs personnalisées sont soumises à des prix spéciaux et requièrent des délais de livraison d'environ 8 à 10 semaines à partir de l'approbation de l'échantillon de couleur.

Wir sind in der Lage nicht nur Platten jeder Größe, sondern auch jedes Farbtone herzustellen. Auf Anfrage ist es nämlich möglich Ihre eigenen Wunschfarben zu gestalten. Mindestbestellmengen für Sonderfarbenanfertigungen können je nach den verlangten Plattenmaßen variieren. Ab Zustimmung der Farbproben benötigen unsere Anfertigungen in kundenspezifischen Farben eine Lieferzeit zwischen 8 und 10 Wochen.

Unsere farbgefertigten Produktionen unterliegen speziellen Preisen.

SOLID COLOURS

760

| cod. | | color | mm | m ² | | pallet |
|-----------------|----------|------------------|-----------------|----------------|------------|--------|
| 12.366.76/0-011 | BETACRYL | Alpi White | 12 x 3660 x 760 | 2,78 | | 15 un. |
| 12.366.76/0-090 | BETACRYL | Igloo White | 12 x 3660 x 760 | 2,78 | | 15 un. |
| 12.366.76/0-101 | BETACRYL | Old Cameo | 12 x 3660 x 760 | 2,78 | | 15 un. |
| 12.366.76/0-110 | BETACRYL | Vanilla Ice | 12 x 3660 x 760 | 2,78 | | 15 un. |
| 12.366.76/0-130 | BETACRYL | Traditional Bone | 12 x 3660 x 760 | 2,78 | | 15 un. |
| 12.366.76/0-140 | BETACRYL | Butter | 12 x 3660 x 760 | 2,78 | | 15 un. |
| 12.366.76/0-700 | BETACRYL | Coffee Brown | 12 x 3660 x 760 | 2,78 | | 15 un. |
| 12.366.76/0-810 | BETACRYL | Cloud Grey | 12 x 3660 x 760 | 2,78 | NEW | 15 un. |
| 12.366.76/0-850 | BETACRYL | Concrete Grey | 12 x 3660 x 760 | 2,78 | | 15 un. |
| 12.366.76/0-999 | BETACRYL | Night Dark | 12 x 3660 x 760 | 2,78 | | 15 un. |
| 12.366.76/9-010 | betalite | Artic White | 12 x 3660 x 760 | 2,78 | | 15 un. |



Le tonalità più scure non sono consigliate per applicazioni che prevedono l'uso intensivo della superficie.

The darkest colour shades are not recommended for applications involving a heavy-duty use of the surface.

Los colores oscuros no se recomiendan para aplicaciones que requieren un uso intenso de la superficie sólida.

Les nuances de couleur foncées ne sont pas recommandées pour des applications qui impliquent l'utilisation intensive de la surface.

Eine Anwendung der dunkelsten Farbtöne wird bei Oberflächen, welche sich durch intensive Nutzung hervorheben, nicht empfohlen.

SOLID COLOURS

930 - 1350

| cod. | | color | mm | m ² | pallet |
|------------------|----------|------------------|------------------|----------------|-------------------|
| 6.366.93/0-090 | BETACRYL | Igloo White | 6 x 3660 x 930 | 3,40 | 30 un. |
| 6.366.93/0-101 | BETACRYL | Old Cameo | 6 x 3660 x 930 | 3,40 | 30 un. |
| 6.366.93/0-110 | BETACRYL | Vanilla Ice | 6 x 3660 x 930 | 3,40 | 30 un. |
| 6.366.93/0-130 | BETACRYL | Traditional Bone | 6 x 3660 x 930 | 3,40 | 30 un. |
| 6.366.93/0-140 | BETACRYL | Butter | 6 x 3660 x 930 | 3,40 | 30 un. |
| 6.366.93/0-700 | BETACRYL | Coffee Brown | 6 x 3660 x 930 | 3,40 | 30 un. |
| 6.366.93/0-710 | BETACRYL | Terra Brown | 6 x 3660 x 930 | 3,40 | 30 un. |
| 6.366.93/0-810 | BETACRYL | Cloud Grey | 6 x 3660 x 930 | 3,40 | 30 un. |
| 6.366.93/0-850 | BETACRYL | Concrete Grey | 6 x 3660 x 930 | 3,40 | 30 un. |
| 6.366.93/0-999 | BETACRYL | Night Dark | 6 x 3660 x 930 | 3,40 | 30 un. |
| 12.366.93/0-090 | BETACRYL | Igloo White | 12 x 3660 x 930 | 3,40 | 15 un. |
| 12.366.93/0-101 | BETACRYL | Old Cameo | 12 x 3660 x 930 | 3,40 | 15 un. |
| 12.366.93/0-110 | BETACRYL | Vanilla Ice | 12 x 3660 x 930 | 3,40 | 15 un. |
| 12.366.93/0-130 | BETACRYL | Traditional Bone | 12 x 3660 x 930 | 3,40 | 15 un. |
| 12.366.93/0-140 | BETACRYL | Butter | 12 x 3660 x 930 | 3,40 | 15 un. |
| 12.366.93/0-700 | BETACRYL | Coffee Brown | 12 x 3660 x 930 | 3,40 | 15 un. |
| 12.366.93/0-710 | BETACRYL | Terra Brown | 12 x 3660 x 930 | 3,40 | 15 un. |
| 12.366.93/0-810 | BETACRYL | Cloud Grey | 12 x 3660 x 930 | 3,40 | 15 un. |
| 12.366.93/0-830 | BETACRYL | Clay Grey | 12 x 3660 x 930 | 3,40 | NEW 15 un. |
| 12.366.93/0-840 | BETACRYL | Smart Grey | 12 x 3660 x 930 | 3,40 | 15 un. |
| 12.366.93/0-850 | BETACRYL | Concrete Grey | 12 x 3660 x 930 | 3,40 | 15 un. |
| 12.366.93/0-999 | BETACRYL | Night Dark | 12 x 3660 x 930 | 3,40 | 15 un. |
| 12.366.135/0-011 | BETACRYL | Alpi White | 12 x 3660 x 1350 | 4,94 | 12 un. |
| 12.366.135/9-010 | betalite | Artic White | 12 x 3660 x 1350 | 4,94 | 12 un. |



Le tonalità più scure non sono consigliate per applicazioni che prevedono l'uso intensivo della superficie.

The darkest colour shades are not recommended for applications involving a heavy-duty use of the surface.

Los colores oscuros no se recomiendan para aplicaciones que requieren un uso intenso de la superficie sólida.

Les nuances de couleur foncées ne sont pas recommandées pour des applications qui impliquent l'utilisation intensive de la surface.

Eine Anwendung der dunkelsten Farbtöne wird bei Oberflächen, welche sich durch intensive Nutzung hervorheben, nicht empfohlen.

VENUS COLOURS

930 - 1520

| cod. | color | mm | m ² | pallet |
|------------------|--------------------------|------------------|----------------|-------------------|
| 12.366.93/5-108 | BETACRYL Victoria | 12 x 3660 x 930 | 3,40 | 15 un. |
| 12.366.93/5-158 | BETACRYL Botticino | 12 x 3660 x 930 | 3,40 | 15 un. |
| 12.366.93/5-848 | BETACRYL Travertino | 12 x 3660 x 930 | 3,40 | 15 un. |
| 12.305.152/5-118 | betalite Carrara White | 12 x 3050 x 1520 | 4,64 | NEW 10 un. |
| 12.305.152/5-818 | betalite Serpentino Grey | 12 x 3050 x 1520 | 4,64 | NEW 10 un. |
| 12.305.152/5-918 | betalite Marquina Black | 12 x 3050 x 1520 | 4,64 | NEW 10 un. |



! Le tonalità più scure non sono consigliate per applicazioni che prevedono l'uso intensivo della superficie.
 The darkest colour shades are not recommended for applications involving a heavy-duty use of the surface.
 Los colores oscuros no se recomiendan para aplicaciones que requieren un uso intenso de la superficie sólida.
 Les nuances de couleur foncées ne sont pas recommandées pour des applications qui impliquent l'utilisation intensive de la surface.
 Eine Anwendung der dunkelsten Farbtöne wird bei Oberflächen, welche sich durch intensive Nutzung hervorheben, nicht empfohlen.

Le venature passanti potrebbero non garantire la continuità del disegno in caso di giunture.
 The through veins may not guarantee the continuity of the design in case of joints.
 Las venas pasantes pueden no garantizar la continuidad del diseño en caso de juntas.
 Les veines traversantes peuvent ne pas garantir la continuité de la conception en cas de joints.
 Die durchgehenden Venen garantieren möglicherweise nicht die Kontinuität der Konstruktion bei Gelenken.

MEDICAL COLOURS



| cod. | color | mm | m ² | pallet |
|------------------|--------------------|-------------------|----------------|--------|
| 3.305.122/0-605 | BETACRYL Surg Blue | 3,5 x 3050 x 1220 | 3,72 | 50 un. |
| 12.305.122/0-605 | BETACRYL Surg Blue | 12 x 3050 x 1220 | 3,72 | 12 un. |

Nella progettazione e nella realizzazione di nuovi ambienti sanitari la priorità è investire nella sicurezza e nel massimo livello di igiene, nella scelta di materiali resistenti e durevoli che permettano ad ogni nuova realizzazione di mantenere inalterata la propria funzionalità nel tempo.

Tutta la produzione BETACRYL® è antibatterica e certificata Euroclass B s1 D0

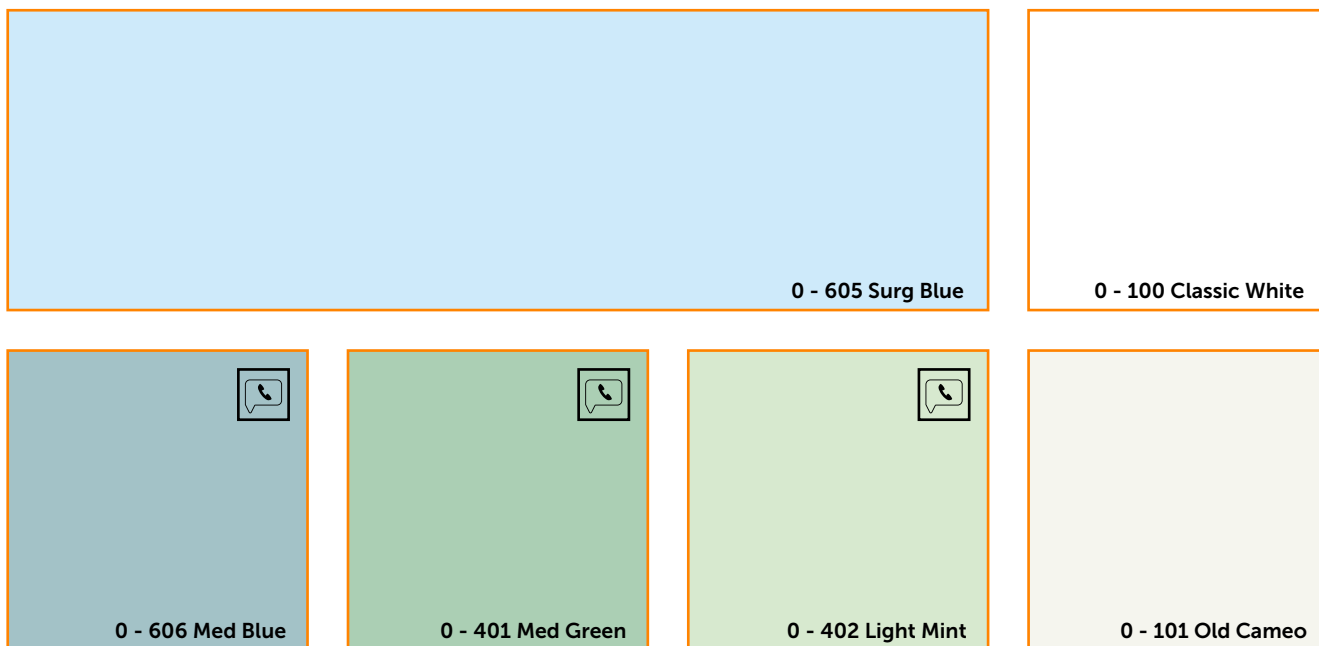

In the design and implementation of new sanitary environments the priority is to guarantee the highest level of safety and hygiene as well as of resistant and durable materials choice, allowing to keep unchanged functionality over time to any project. The entire BETACRYL® production is antibacterial and certified Euroclass B s1 D0

En el diseño y construcción de nuevos entornos de atención médica, la prioridad es invertir en seguridad y en el más alto nivel de higiene, en la elección de materiales resistentes y duraderos que permitan que cada nueva construcción mantenga su funcionalidad a lo largo del tiempo. Toda la producción de BETACRYL® es antibacteriana y cuenta con la certificación Euroclass B s1 D0.

Dans la conception et la construction de nouveaux environnements de soins, la priorité est d'investir dans la sécurité et le plus haut niveau d'hygiène, dans le choix de matériaux résistants et durables qui permettent à chaque nouvelle construction de maintenir sa fonctionnalité inchangée dans le temps. La production de BETACRYL® est antibactérienne et certifiée Euroclasse B s1 D0

Bei der Konzeption und Implementierung neuer sanitärer Umgebungen besteht die Priorität darin, ein Höchstmaß an Sicherheit und Hygiene sowie eine Auswahl an widerstandsfähigen und langlebigen Materialien zu gewährleisten, damit die Funktionalität für jedes Projekt über die Zeit unverändert bleibt. Die gesamte BETACRYL®-Produktion ist antibakteriell und Euroclass B s1 D0 zertifiziert



Su richiesta | On request | A petición | Sur demande | Auf Anfrage || [Pag. 15 & 27](#)

A close-up photograph of a white kitchen sink. A chrome faucet with a high-arched, flexible gooseneck is positioned on the right side. A black soap dispenser with two yellow soap bars is mounted on the sink's edge. The background is a light blue wall. The text 'LAVELLI DA CUCINA' is centered over the sink, with a small orange horizontal line below it. Below the line, the text 'KITCHEN SINKS', 'FREGADEROS DE COCINA', 'EVIERS DE CUISINE', and 'KÜCHENSPILE' is listed in a smaller font.

LAVELLI DA CUCINA

KITCHEN SINKS
FREGADEROS DE COCINA
EVIERS DE CUISINE
KÜCHENSPILE

BS 1635

0-100
CLASSIC WHITE

0-101
OLD CAMEO

0-130
TRADITIONAL BONE

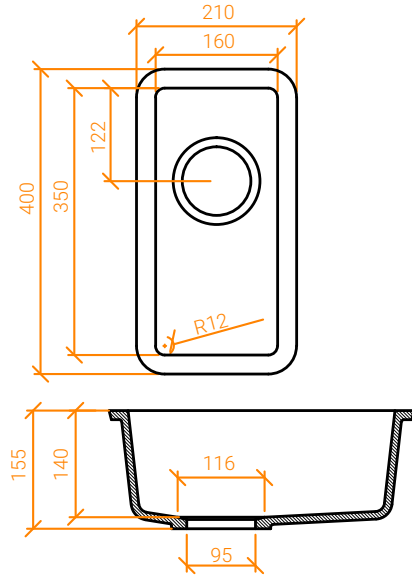

| | | | | | |
|------|---|---|-----|-----|-----|
| Kg 4 | → | ← | 400 | 210 | 155 |
| | ← | → | 350 | 160 | 140 |



BS 3030

0-100
CLASSIC WHITE

0-101
OLD CAMEO

0-130
TRADITIONAL BONE

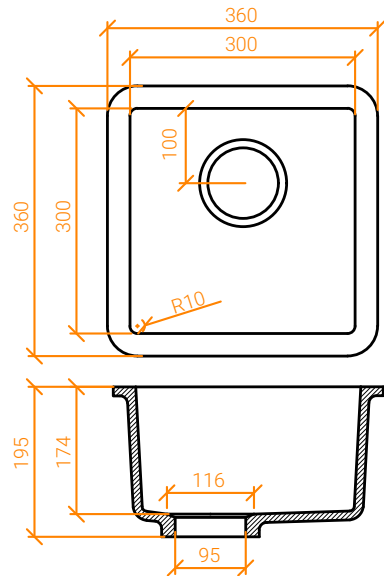

| | | | | | |
|------|---|---|-----|-----|-----|
| Kg 6 | → | ← | 360 | 360 | 195 |
| | ← | → | 300 | 300 | 174 |

BS 3440

0-100
CLASSIC WHITE

0-101
OLD CAMEO

0-130
TRADITIONAL BONE

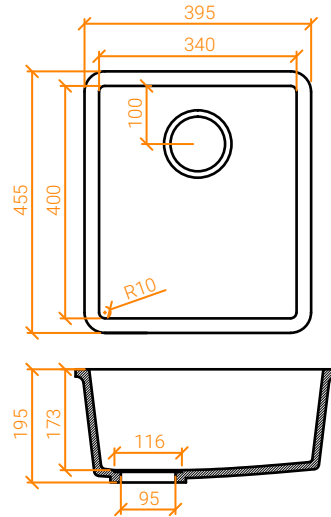

Kg 8 →| |← 455 395 195
 |← →| 400 340 173



BS 4040

0-100
CLASSIC WHITE

0-101
OLD CAMEO

0-130
TRADITIONAL BONE

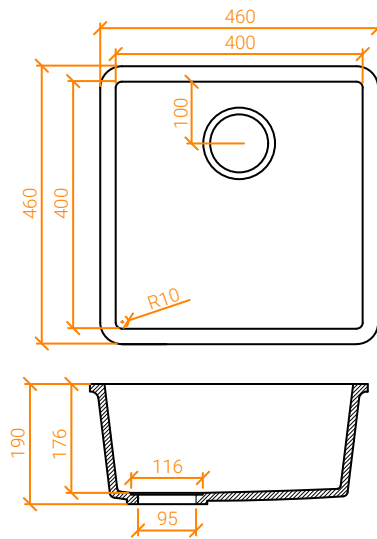

Kg 12 →| |← 460 460 190
 |← →| 400 400 176

BS 4540

0-100
CLASSIC WHITE

0-101
OLD CAMEO

0-130
TRADITIONAL BONE

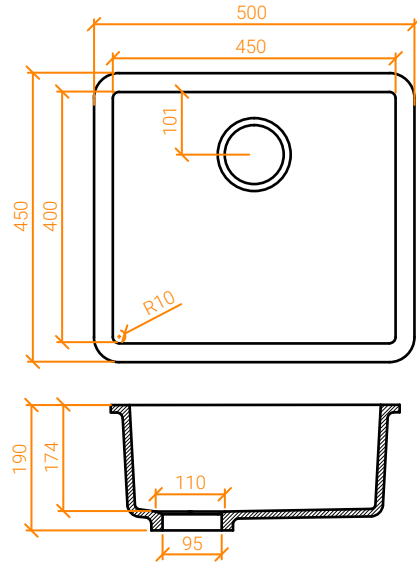

Kg 13 →| |← 450 500 190
 |← →| 400 450 174



BS 5340

0-100
CLASSIC WHITE

0-101
OLD CAMEO

0-130
TRADITIONAL BONE

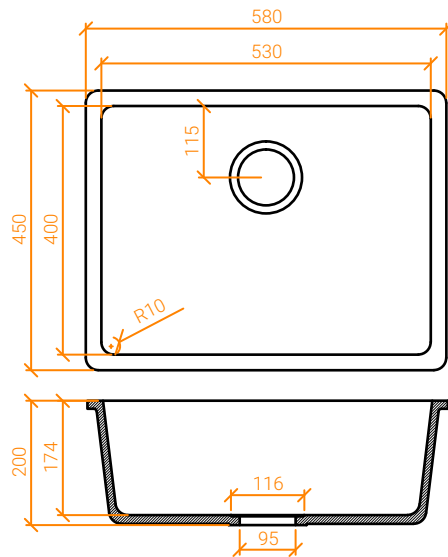

Kg 15 →| |← 450 580 200
 |← →| 400 530 174

BS 7040

0-100
CLASSIC WHITE

0-101
OLD CAMEO

0-130
TRADITIONAL BONE

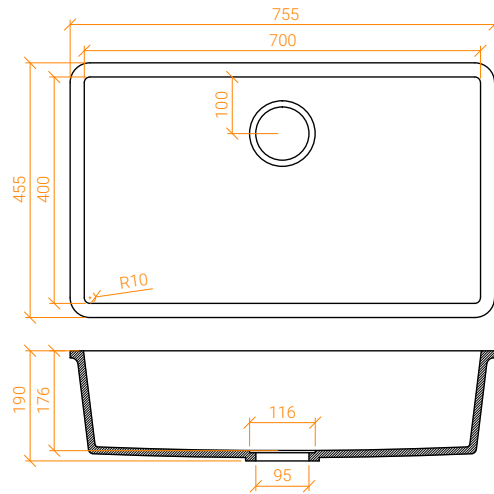

Kg 18 →| |← 455 755 190
 |← →| 400 700 176



BS D 7740

0-100
CLASSIC WHITE

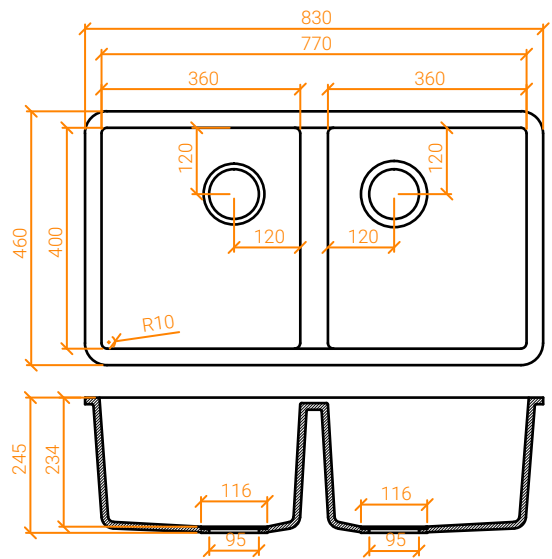

Kg 21 →| |← 460 830 245
 |← →| 400 770 234

BS 4040 R

0-100
CLASSIC WHITE

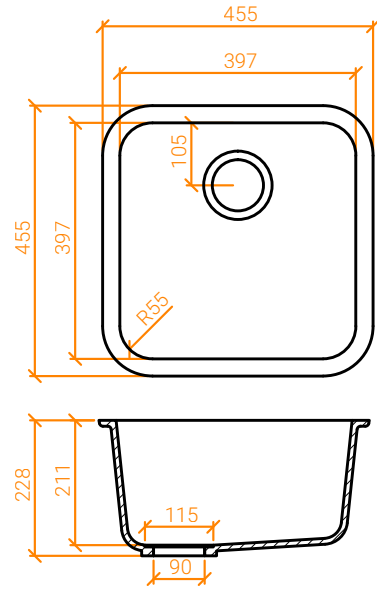

| | | | | | |
|------|---|---|-----|-----|-----|
| Kg 8 | → | ← | 455 | 455 | 228 |
| | ← | → | 397 | 397 | 211 |



BS 5340 R

0-100
CLASSIC WHITE

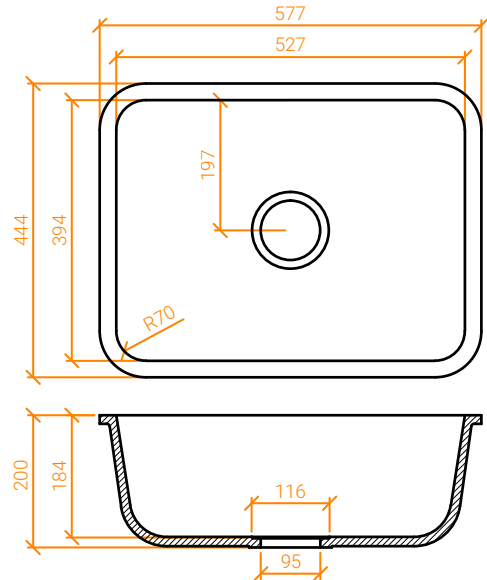

| | | | | | |
|-------|---|---|-----|-----|-----|
| Kg 15 | → | ← | 444 | 577 | 200 |
| | ← | → | 394 | 527 | 184 |

BS RD 7950

0-100
CLASSIC WHITE

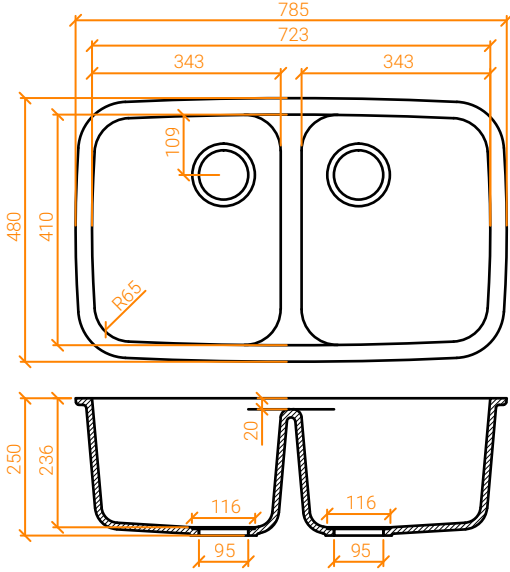

| | | | | | |
|-------|---|---|-----|-----|-----|
| Kg 24 | → | ← | 480 | 785 | 250 |
| | ← | → | 410 | 723 | 236 |



LAVABI DA BAGNO INTEGRABILI

BULTIN WASHBOWLS
FREGADEROS INTEGRADOS
LAVABOS INTÉGRÉS
EINGEBAUTE WASCHBECKEN

BB R 375 INT

0-100
CLASSIC WHITE

0-101
OLD CAMEO

0-130
TRADITIONAL BONE

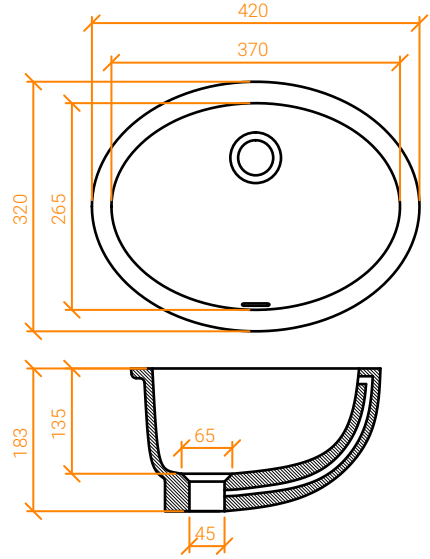

Kg 5 $\rightarrow|$ $| \leftarrow$ 320 420 183
 $| \leftarrow$ $\rightarrow|$ 265 370 135



BB R 430 INT

0-100
CLASSIC WHITE

0-101
OLD CAMEO

0-130
TRADITIONAL BONE

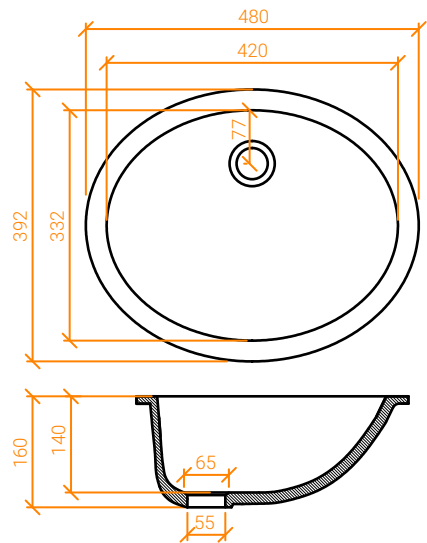

Kg 4 $\rightarrow|$ $| \leftarrow$ 392 480 160
 $| \leftarrow$ $\rightarrow|$ 332 420 140

BB R 455 INT

0-100
CLASSIC WHITE

0-101
OLD CAMEO

0-130
TRADITIONAL BONE

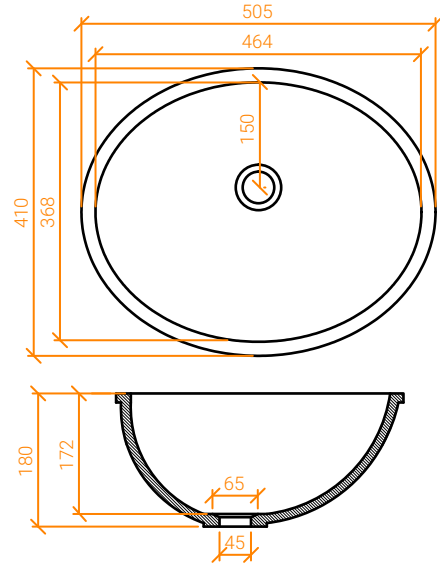

Kg 5 →| |← 410 505 180
 |← →| 368 464 172



BB R 515 INT

0-100
CLASSIC WHITE

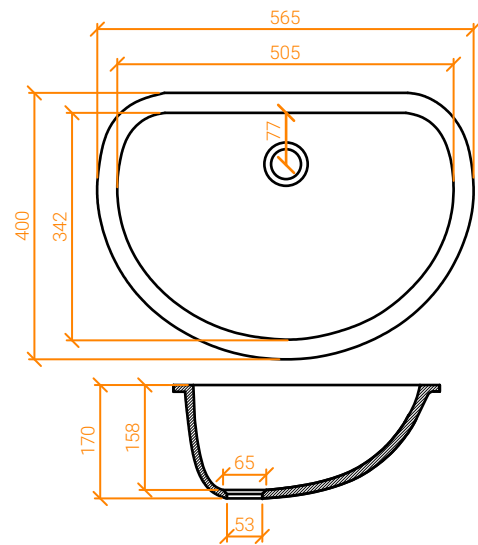

Kg 8 →| |← 400 565 170
 |← →| 342 505 158

BB R 400 INT

0-100
CLASSIC WHITE

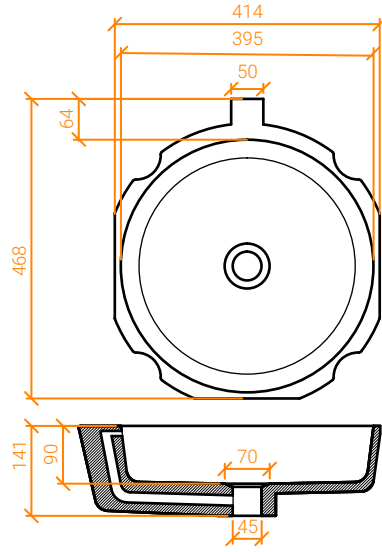

Kg 7 $\rightarrow|$ $| \leftarrow$ 468 414 141
 $| \leftarrow$ $\rightarrow|$ 395 395 90



BB R 420 PMR

0-100
CLASSIC WHITE

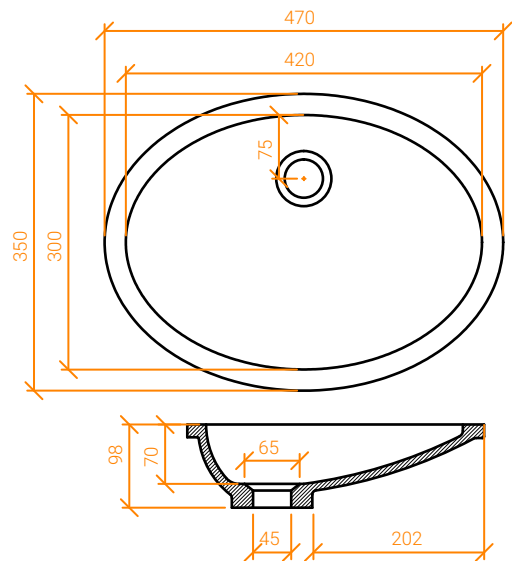

Kg 4 $\rightarrow|$ $| \leftarrow$ 350 470 98
 $| \leftarrow$ $\rightarrow|$ 300 420 70

BB R 5328

0-100
CLASSIC WHITE

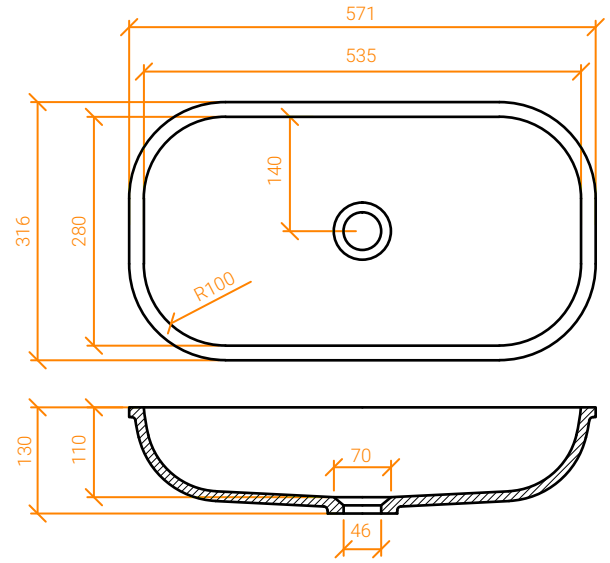

Kg 6 $\rightarrow|$ $| \leftarrow$ 316 571 130
 $| \leftarrow$ $\rightarrow|$ 280 535 110



BB R 5337

0-100
CLASSIC WHITE

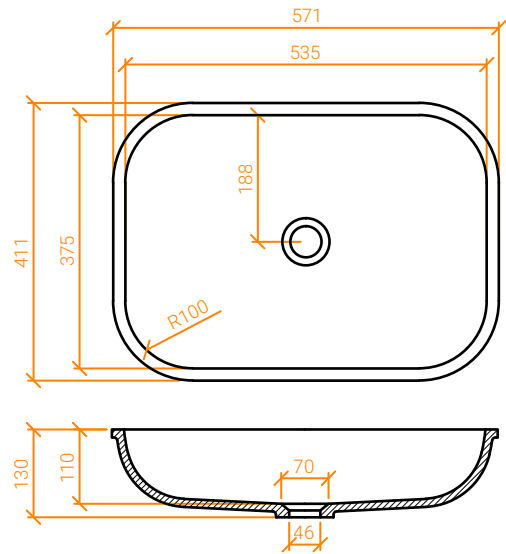

Kg 7 $\rightarrow|$ $| \leftarrow$ 411 571 130
 $| \leftarrow$ $\rightarrow|$ 375 535 110

BB R 4335 TP

0-100
CLASSIC WHITE

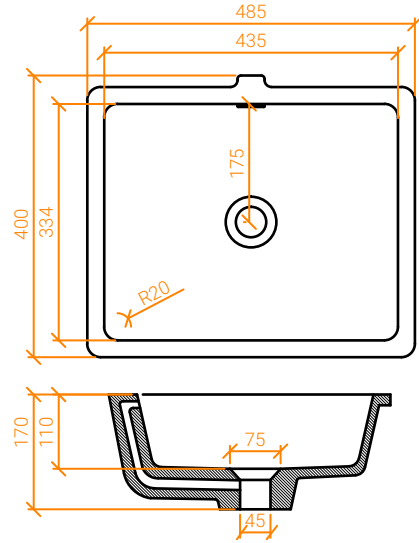

| | | | | | |
|------|---|---|-----|-----|-----|
| Kg 9 | → | ← | 400 | 485 | 170 |
| | ← | → | 334 | 435 | 110 |



BB R 3024

0-100
CLASSIC WHITE

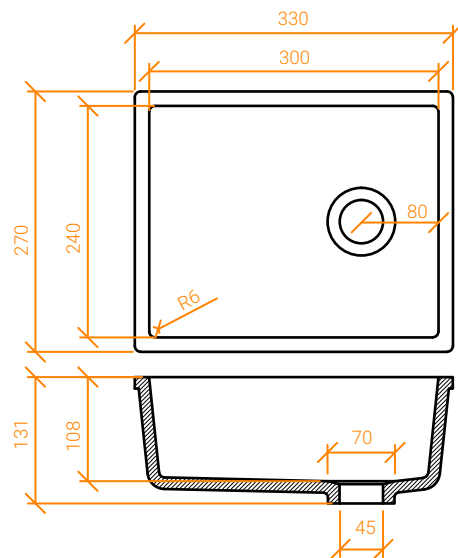

| | | | | | |
|------|---|---|-----|-----|-----|
| Kg 6 | → | ← | 270 | 330 | 131 |
| | ← | → | 240 | 300 | 108 |

BB R 4022

0-100
CLASSIC WHITE

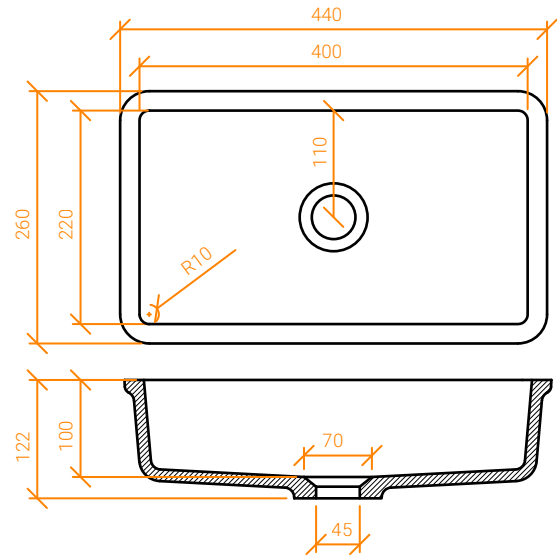

Kg 5 $\rightarrow|$ $| \leftarrow$ 260 440 122
 $| \leftarrow$ $\rightarrow|$ 220 400 100



BB R 614

0-100
CLASSIC WHITE

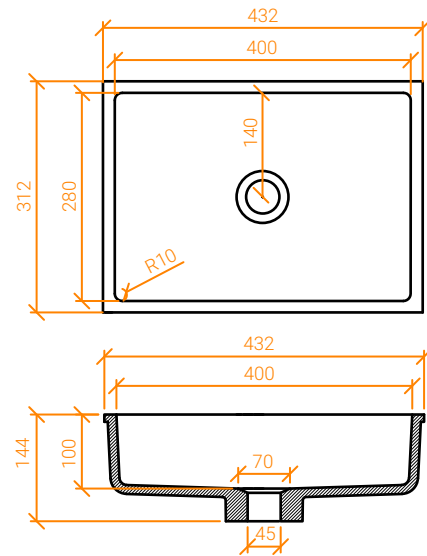

Kg 6 $\rightarrow|$ $| \leftarrow$ 312 432 144
 $| \leftarrow$ $\rightarrow|$ 280 400 100

BB R 615

0-100
CLASSIC WHITE

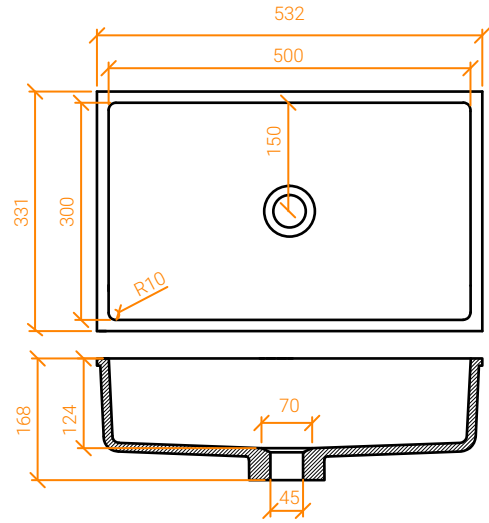

Kg 7 $\rightarrow|$ $| \leftarrow$ 331 532 168
 $| \leftarrow$ $\rightarrow|$ 300 500 124



BB R 619

0-100
CLASSIC WHITE

0-101
OLD CAMEO

0-130
TRADITIONAL BONE

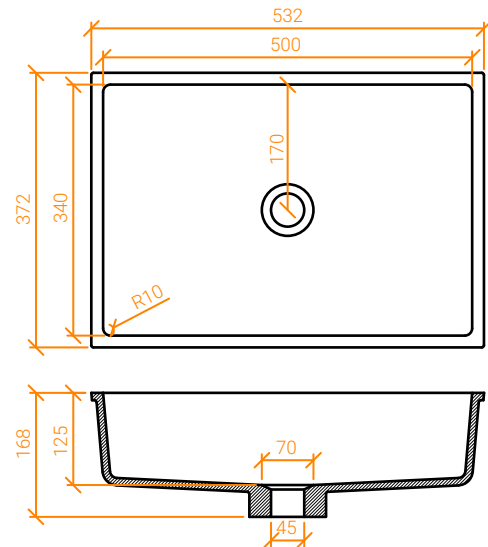

Kg 8 $\rightarrow|$ $| \leftarrow$ 372 532 168
 $| \leftarrow$ $\rightarrow|$ 340 500 125

BB R 617

0-100
CLASSIC WHITE

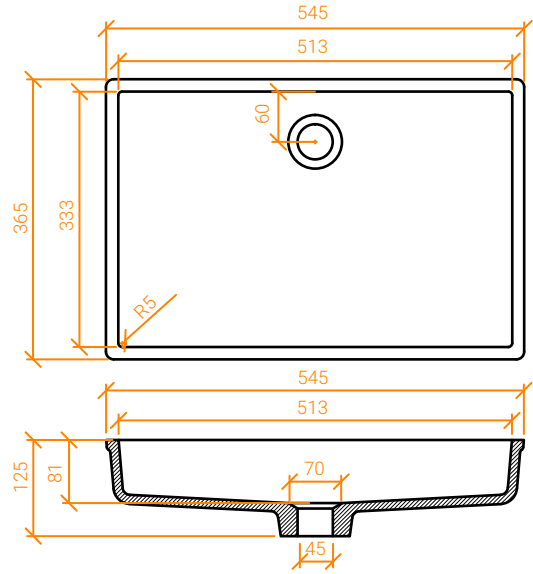

Kg 8 →| |← 365 545 125
 |← →| 333 513 81



BB R 616

0-100
CLASSIC WHITE

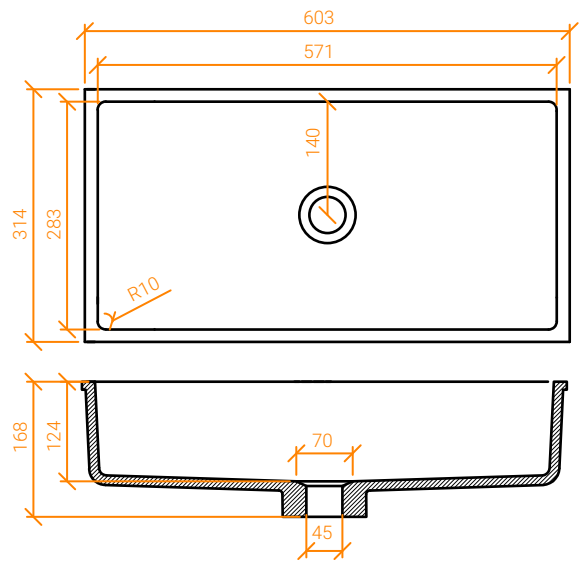

Kg 7 →| |← 314 603 168
 |← →| 283 571 124

BB R 620

0-100
CLASSIC WHITE

0-101
OLD CAMEO

0-130
TRADITIONAL BONE

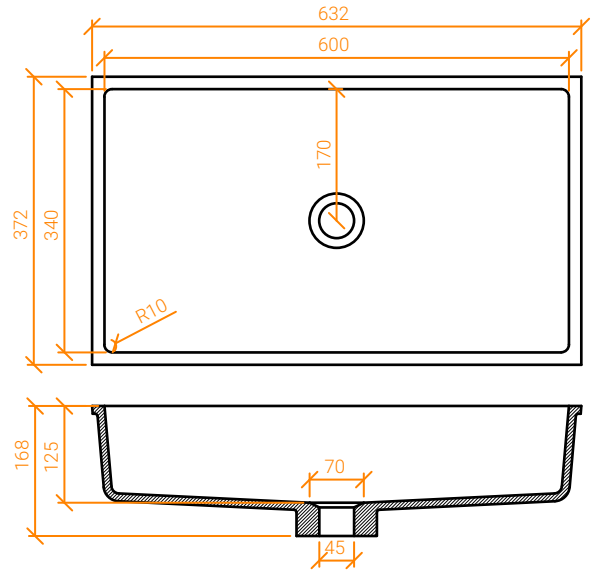

Kg 10 →| |← 372 632 168
 |← →| 340 600 125



BB R 618

0-100
CLASSIC WHITE

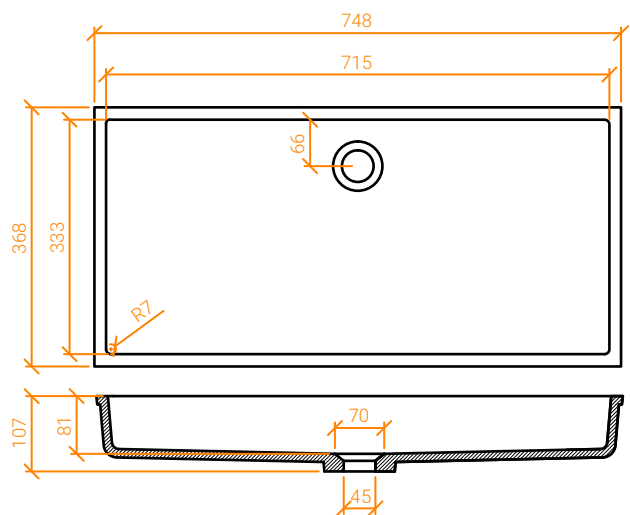

Kg 12 →| |← 368 748 107
 |← →| 333 715 81

BB R 5038

0-100
CLASSIC WHITE

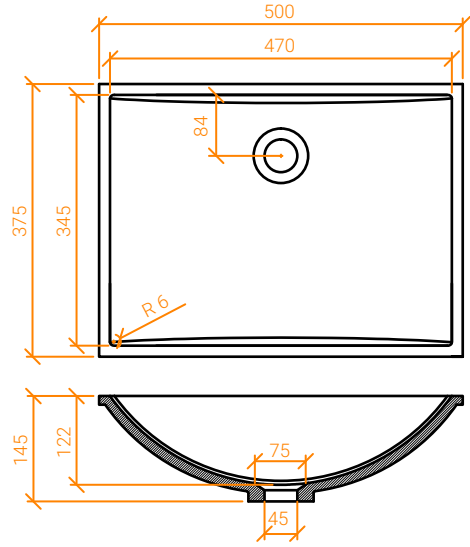

Kg 7 →| |← 375 500 145
 |← →| 345 470 122



BB R 8038

0-100
CLASSIC WHITE

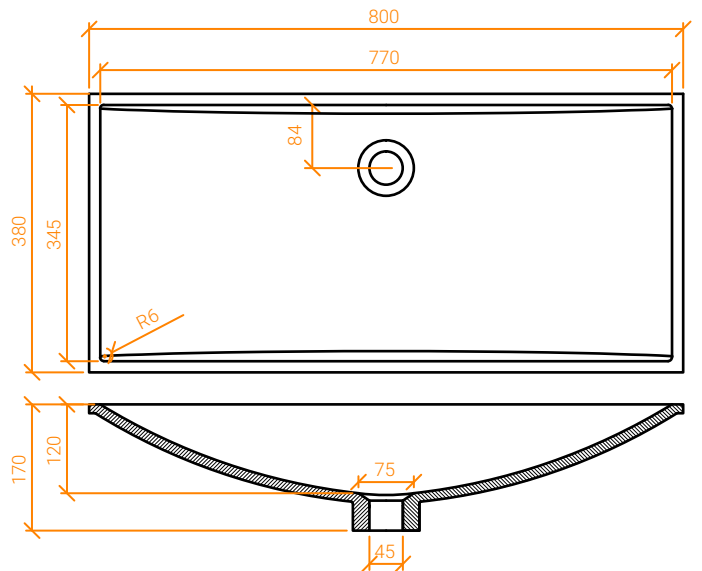

Kg 11 →| |← 380 800 170
 |← →| 345 770 120

BB R 675 PMR

0-100
CLASSIC WHITE

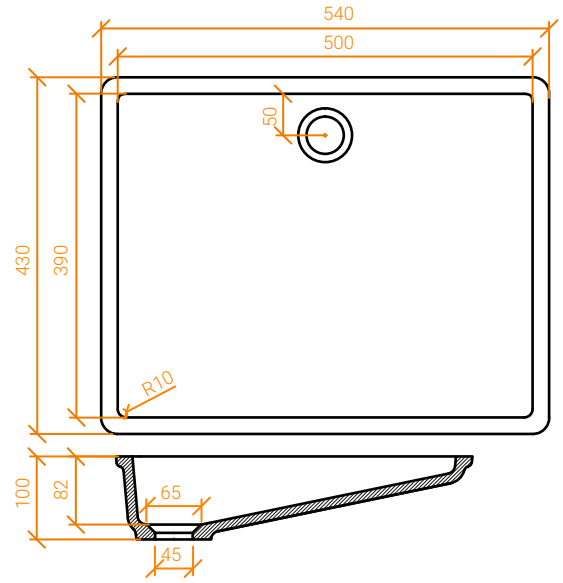

Kg 7 $\rightarrow|$ $| \leftarrow$ 430 540 100
 $| \leftarrow$ $\rightarrow|$ 390 500 82



BB R 670 PMR

0-100
CLASSIC WHITE

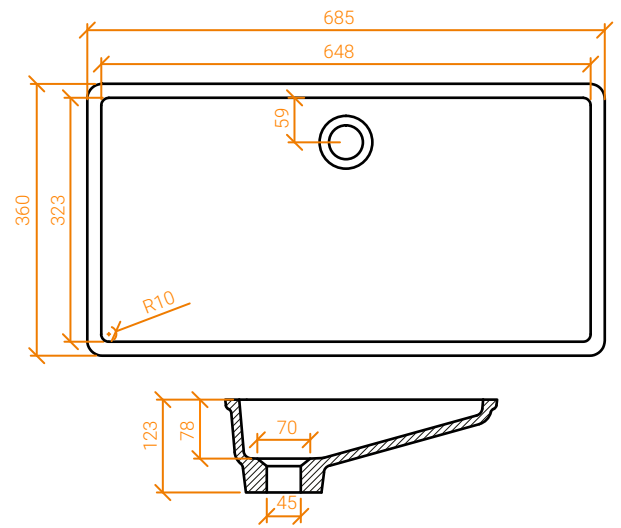

Kg 7 $\rightarrow|$ $| \leftarrow$ 360 685 123
 $| \leftarrow$ $\rightarrow|$ 323 648 78

BB R 5029 PMR

0-100
CLASSIC WHITE

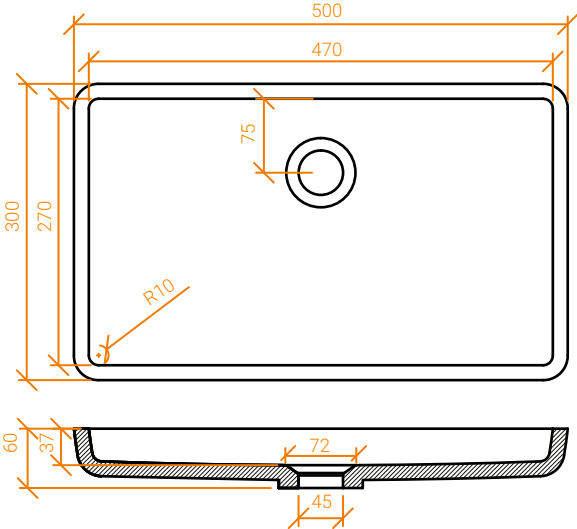

| | | | | | |
|------|---|---|-----|-----|----|
| Kg 4 | → | ← | 300 | 500 | 60 |
| | ← | → | 270 | 470 | 37 |

A high-angle photograph of a white, freestanding bathroom sink. The sink is set on a light-colored, possibly stone or concrete, countertop. In the background, a wall with a rough, stone-like texture is visible, featuring a chrome faucet and two circular wall-mounted fixtures. To the left of the sink, a bar of yellow soap sits on a white soap dish. The overall aesthetic is clean and modern.

LAVABI DA BAGNO DA APPOGGIO

FREESTANDING BATHROOM BASINS
LAVABOS DE BAÑO
LAVABOS POUR SALLE DE BAIN À POSER
BADEZIMMER WASCHECKEN

BB A 400 R

0-100
CLASSIC WHITE

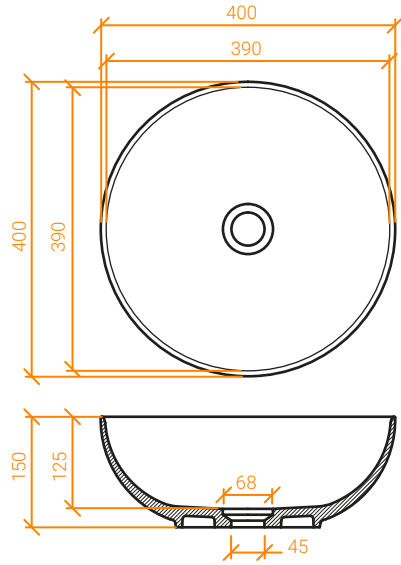

Kg 5 $\rightarrow|$ $| \leftarrow$ 400 400 150
 $| \leftarrow$ $\rightarrow|$ 390 390 125



BB A 420 R

0-100
CLASSIC WHITE

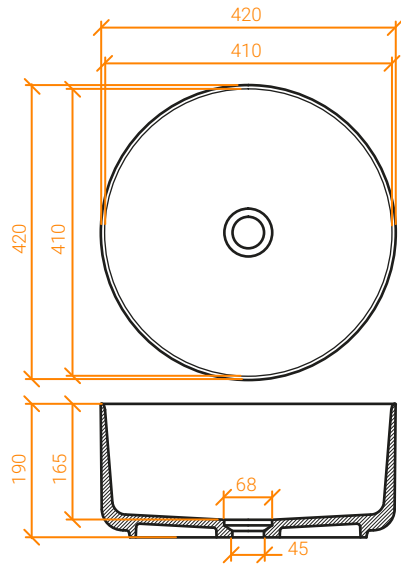

Kg 8 $\rightarrow|$ $| \leftarrow$ 420 420 190
 $| \leftarrow$ $\rightarrow|$ 410 410 165

BB A 450 R

0-100
CLASSIC WHITE

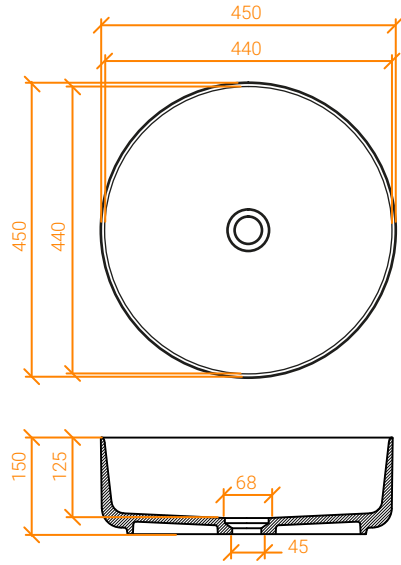

Kg 7 →| |← 450 450 150
 |← →| 440 440 125



BB A 6038 O

0-100
CLASSIC WHITE

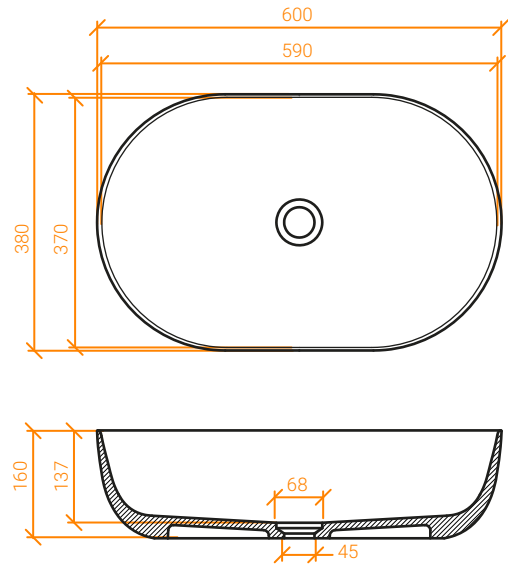

Kg 9 →| |← 380 600 160
 |← →| 370 590 137

BB A 5538 R

0-100
CLASSIC WHITE

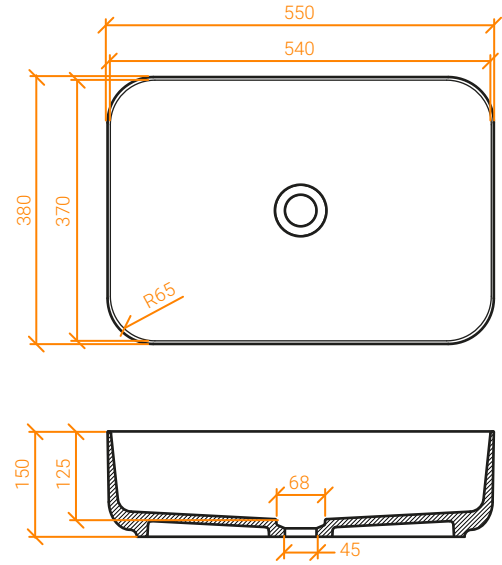

Kg 10 →| |← 380 550 150
 |← →| 370 540 125



BB A 5542 R

0-100
CLASSIC WHITE

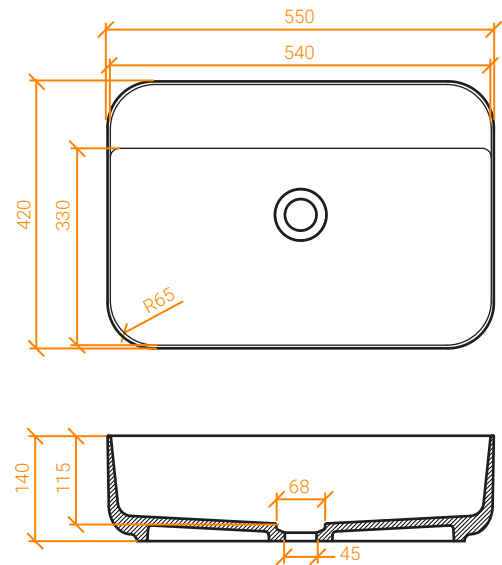

Kg 13 →| |← 420 550 140
 |← →| 330 540 115

BB R 3730 B

0-100
CLASSIC WHITE

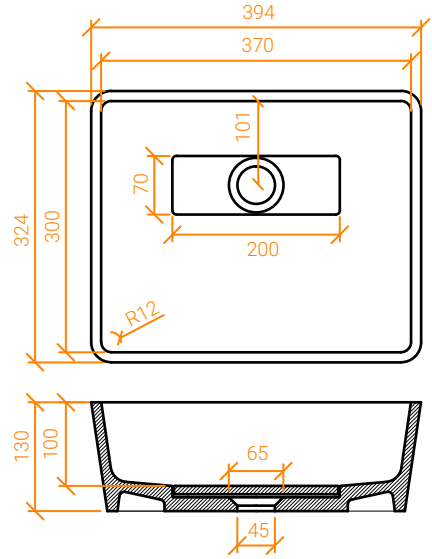

Kg 6



324
300

394
370

130
100



BB R 6130 B

0-100
CLASSIC WHITE

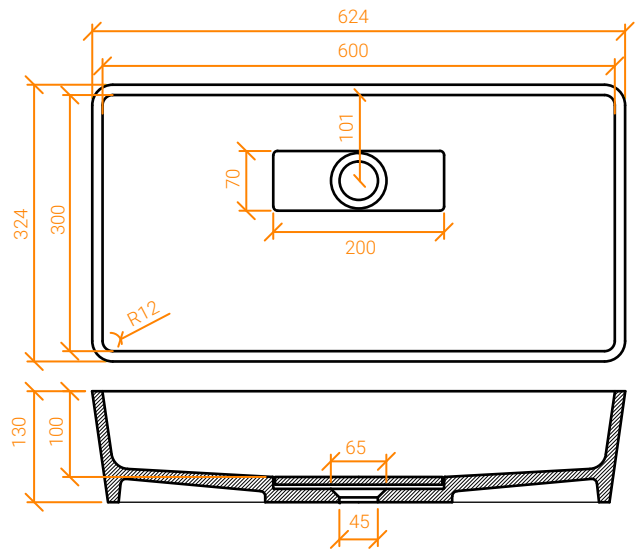

Kg 9



324
300

624
600

130
100

BB R 7030 B

0-100
CLASSIC WHITE

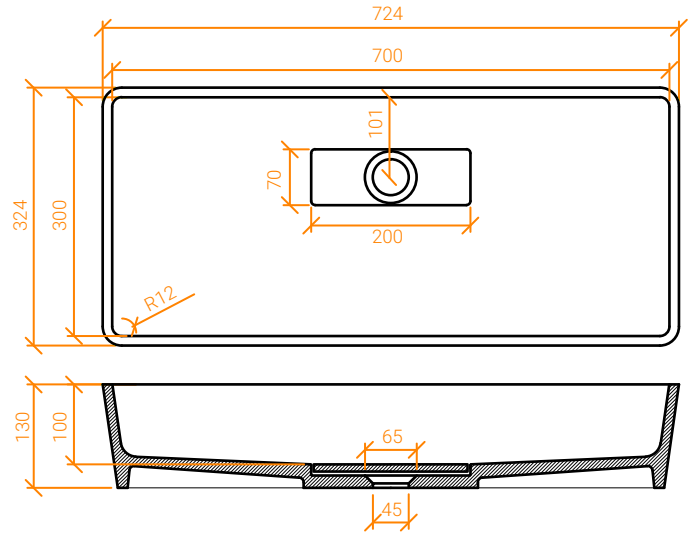

| | | | | | | |
|---|-------|---|---|-----|-----|-----|
| ↓ | Kg 11 | → | ← | 324 | 724 | 130 |
| ↑ | | ← | → | 300 | 700 | 100 |



BB R 409

0-100
CLASSIC WHITE

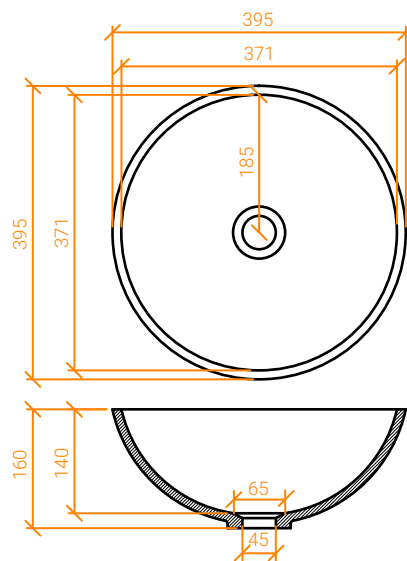

| | | | | | | |
|---|------|---|---|-----|-----|-----|
| ↓ | Kg 6 | → | ← | 395 | 395 | 160 |
| ↑ | | ← | → | 371 | 371 | 140 |

BB R 379

0-100
CLASSIC WHITE

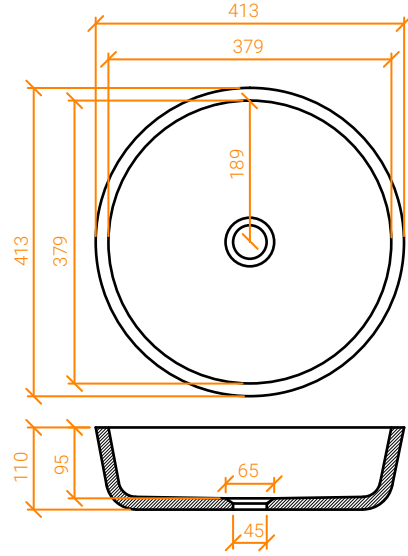

Kg 7 →| |← 413 413 110
 |← →| 379 379 95



BB A 6035 Y

0-100
CLASSIC WHITE

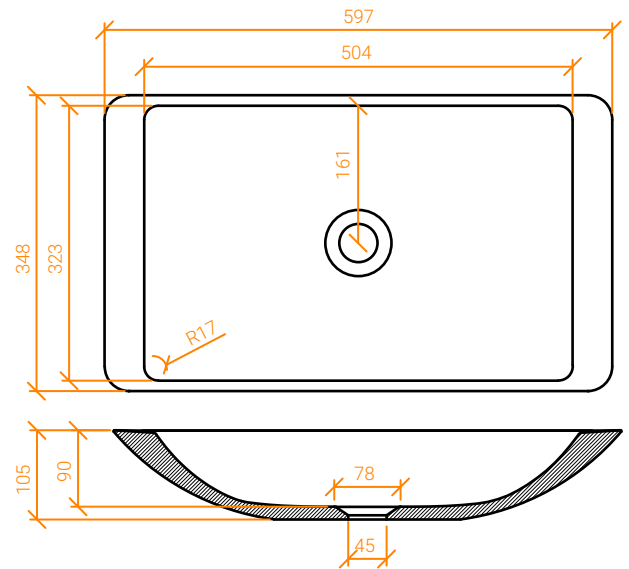

Kg 10 →| |← 348 597 105
 |← →| 323 504 90

BB R 406

0-100
CLASSIC WHITE

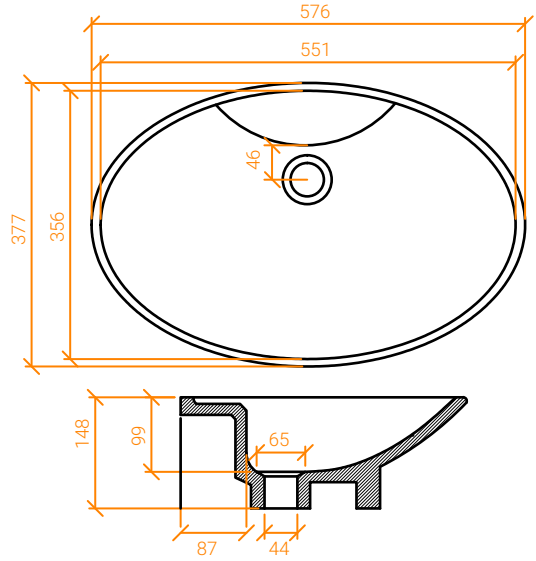

| | | | | | |
|------|---|---|-----|-----|-----|
| Kg 7 | → | ← | 377 | 576 | 148 |
| | ← | → | 356 | 551 | 99 |



BB R 3024 B

0-100
CLASSIC WHITE

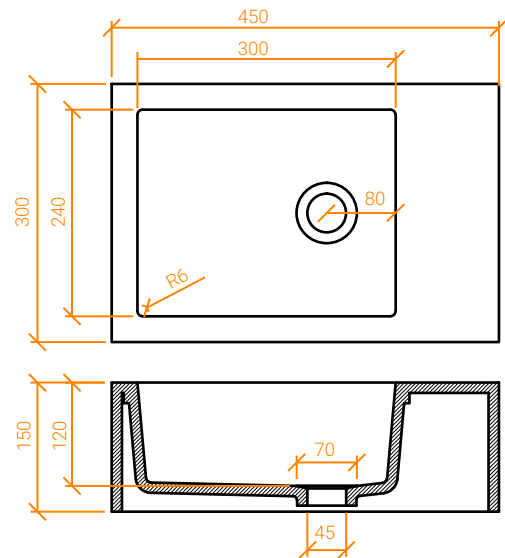

| | | | | | |
|------|---|---|-----|-----|-----|
| Kg 9 | → | ← | 300 | 450 | 150 |
| | ← | → | 240 | 300 | 120 |

BB R 365 B

0-100
CLASSIC WHITE

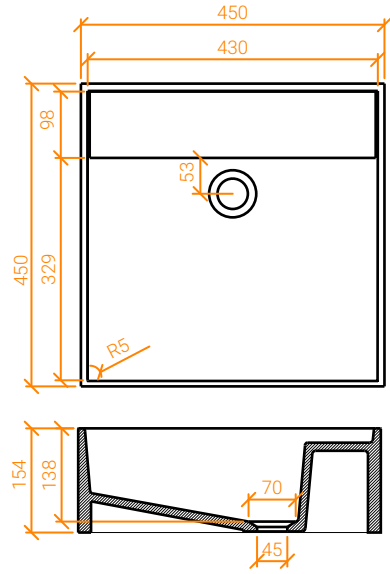

Kg 12 →| |← 450 450 154
 |← →| 329 430 138



BB R 366

0-100
CLASSIC WHITE

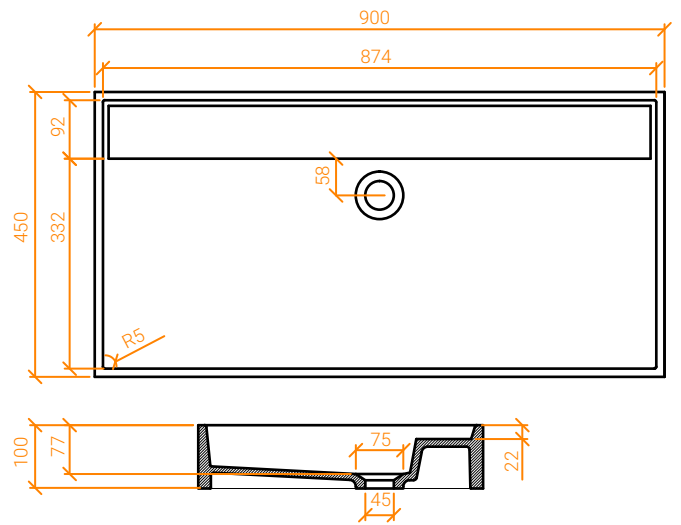

Kg 20 →| |← 450 900 100
 |← →| 332 874 77

BB R 915

0-100
CLASSIC WHITE

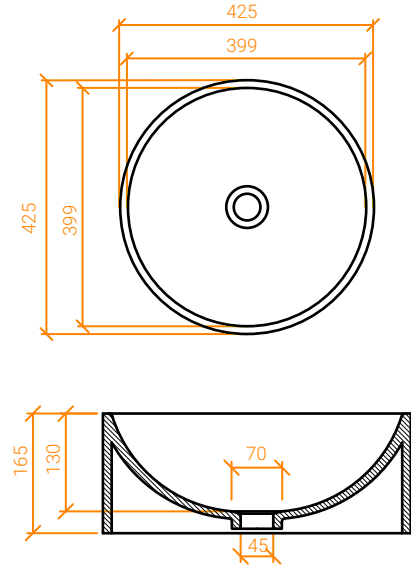

Kg 10 →| |← 425 425 165
 |← →| 399 399 130



BB R 920

0-100
CLASSIC WHITE

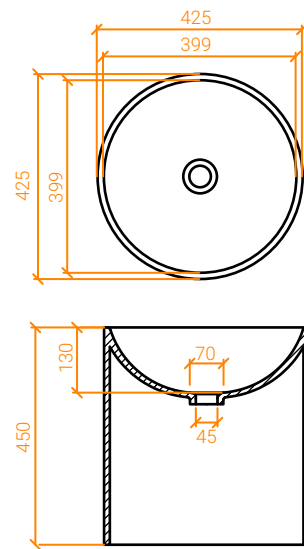

Kg 15 →| |← 425 425 450
 |← →| 399 399 130

BB A 6535 O

0-100
CLASSIC WHITE

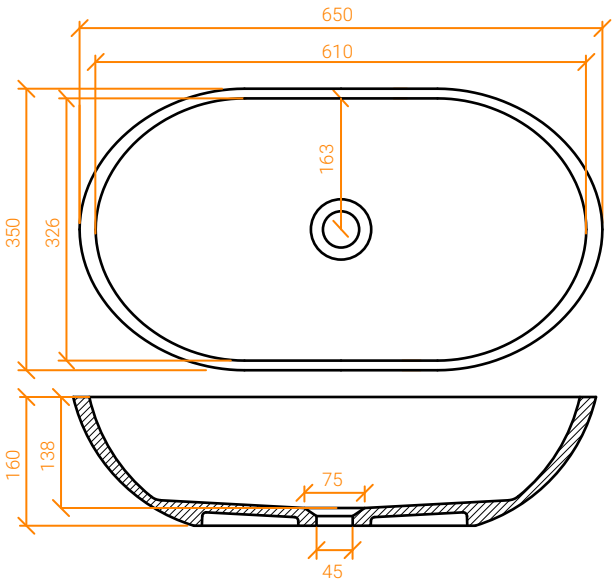

| | | | | | |
|-------|---|---|-----|-----|-----|
| Kg 10 | → | ← | 350 | 650 | 160 |
| | ← | → | 326 | 610 | 138 |

BB A 800 LGA

0-100
CLASSIC WHITE

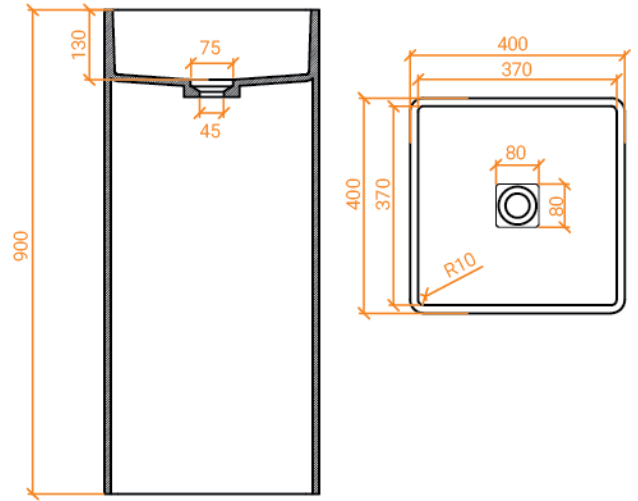

Kg 40 $\rightarrow|$ $| \leftarrow$ 400 400 900
 $| \leftarrow$ $\rightarrow|$ 370 370 130



BB R 926

0-100
CLASSIC WHITE

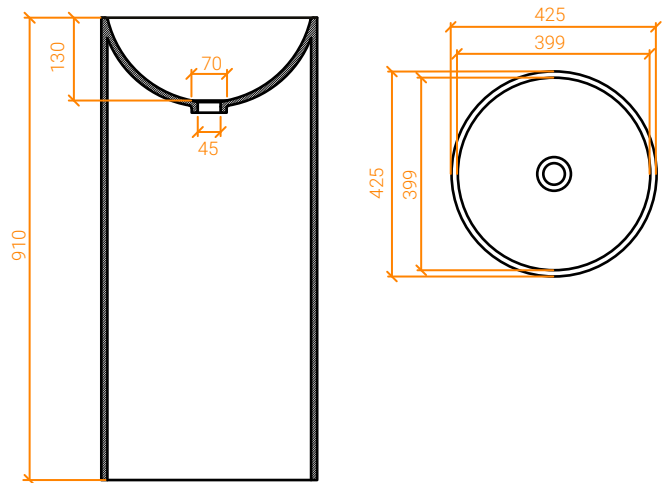

Kg 30 $\rightarrow|$ $| \leftarrow$ 425 425 910
 $| \leftarrow$ $\rightarrow|$ 399 399 130



VASCHE DA BAGNO

BATHTUBS
BAÑERAS
BAIGNOIRES
BADEWANNEN

B-Tub O 1550

0-100
CLASSIC WHITE

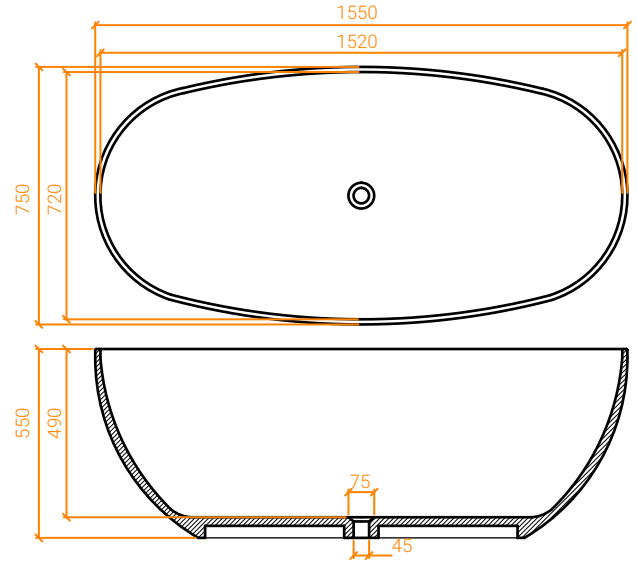

Kg 100 →| |← 750 1550 550
 |← →| 720 1520 490



B-Tub O 1650

0-100
CLASSIC WHITE

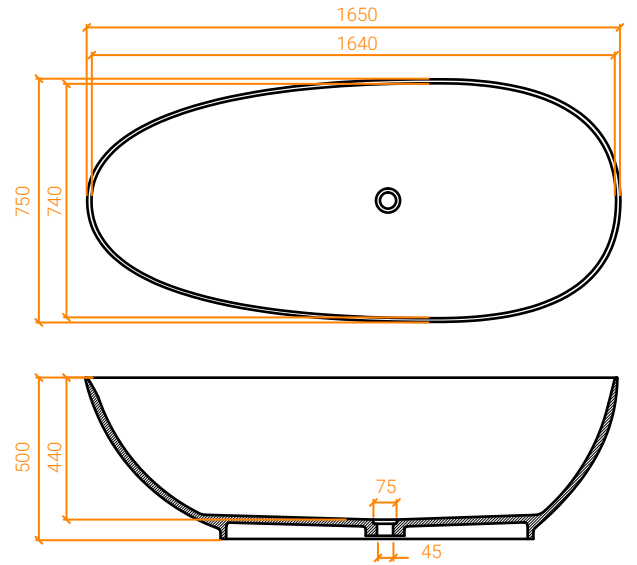

Kg 100 →| |← 750 1650 500
 |← →| 740 1640 440

B-Tub O 1750

0-100
CLASSIC WHITE

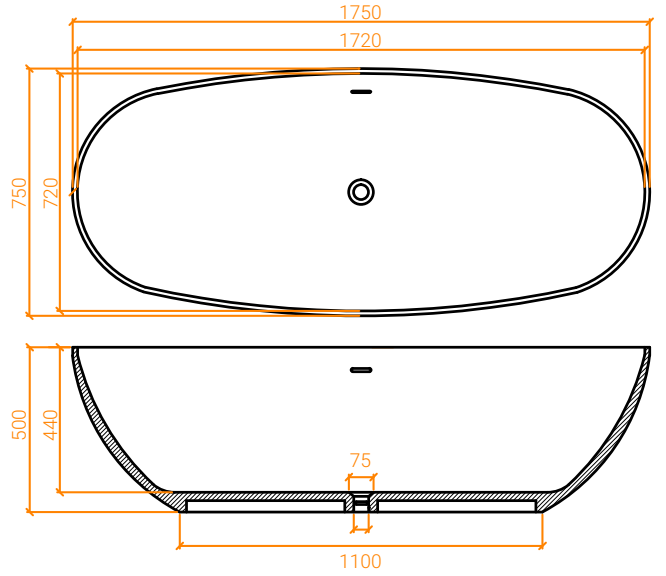

Kg 105 →| |← 750 1750 500
 |← →| 720 1720 440



B-Tub O 1695

0-100
CLASSIC WHITE

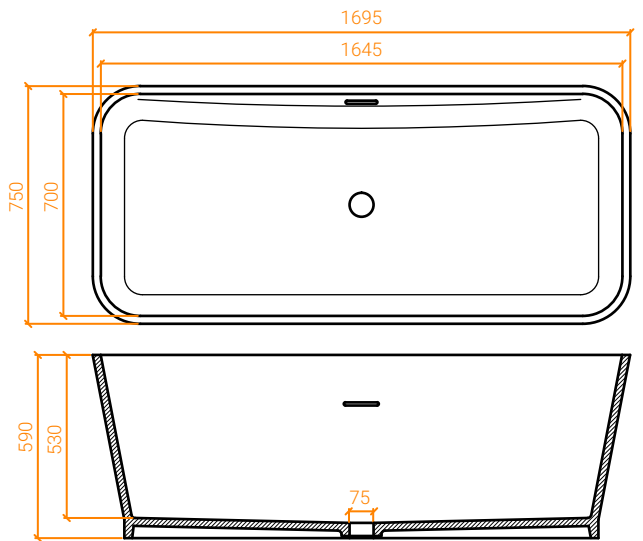

Kg 120 →| |← 750 1695 590
 |← →| 700 1645 530

B-Tub G 1600

0-100
CLASSIC WHITE

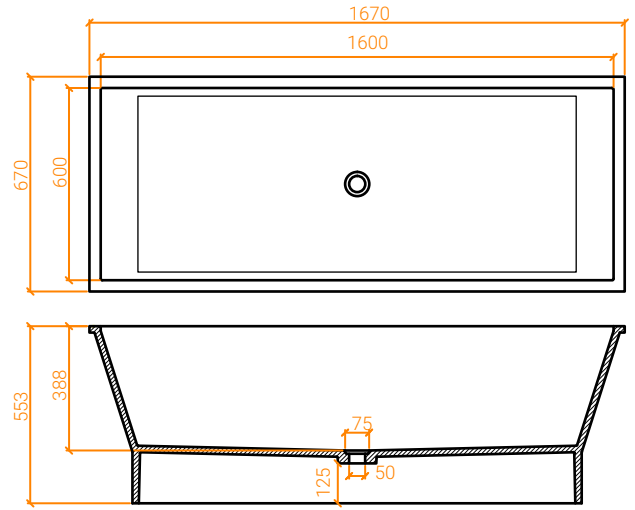

Kg 130 →| |← 670 1670 553
 |← →| 600 1600 388



B-Tub G 1950 B

0-100
CLASSIC WHITE

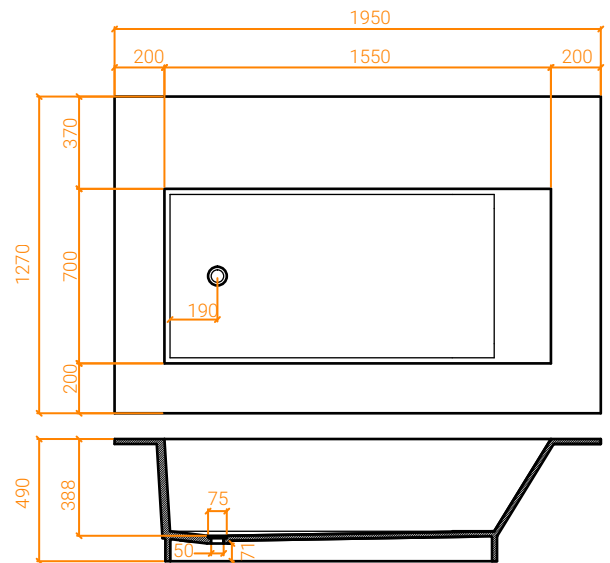

Kg 170 →| |← 1270 1950 490
 |← →| 700 1550 388

B-Tub G 2100 B

0-100
CLASSIC WHITE

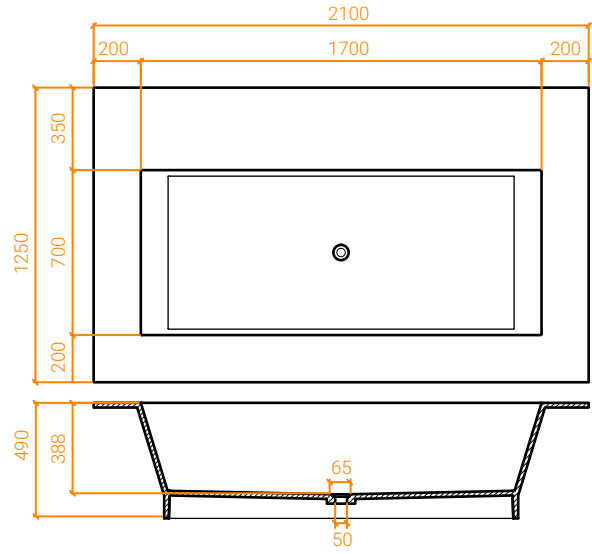

Kg 180 →| |← 1250 2100 490
 |← →| 700 1700 388



B-Tub G 1800

0-100
CLASSIC WHITE

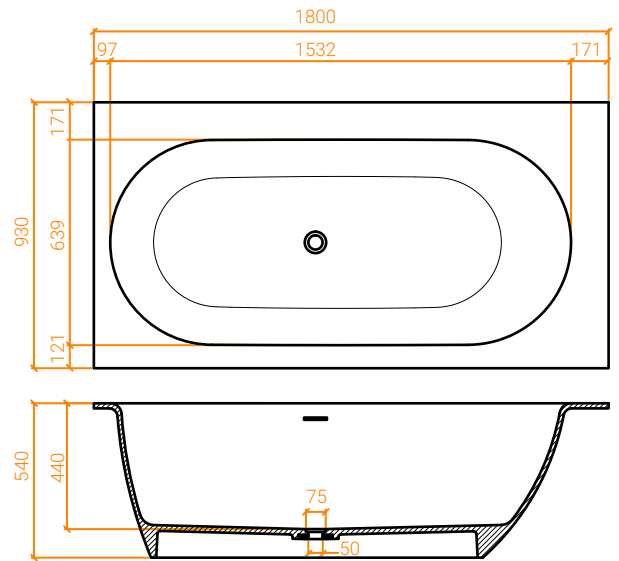

Kg 155 →| |← 930 1800 540
 |← →| 639 1532 440

B-Tub GO 1700

0-100
CLASSIC WHITE

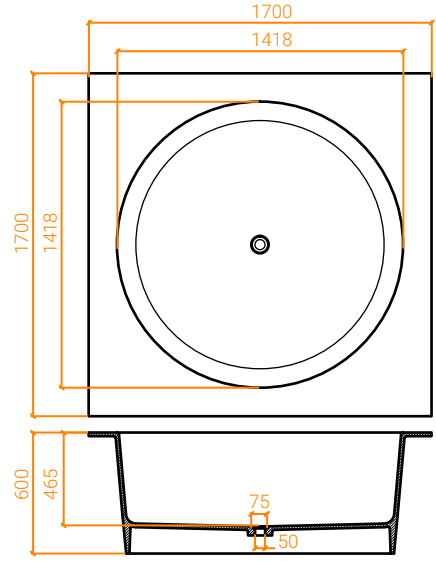

Kg 270 →| |← 1700 1700 600
 |← →| 1418 1418 465



SPAZIO MINIMO DI INSTALLAZIONE SCARICO
 WASTE SYSTEM MINIMUM ROOM
 ESPACIO MÍNIMO DEL SISTEMA DE DESAGUE
 ESPACE MINIMUM POUR LE VIDAGE
 ABFALLSYSTEM MINDESTRAUM

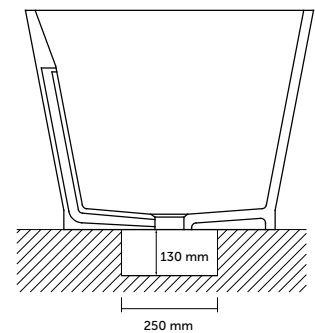
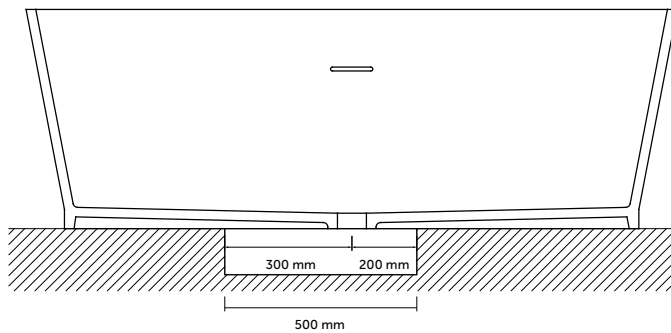

LAVABI PROFESSIONALI E PER DISABILI

PROFESSIONAL BASINS AND FOR DISABLED
LAVABOS PROFESIONALES Y POR DESECAPACITADOS
LAVABOS PROFESSIONNELS ET PMR
PROFESSIONELLE UND BEHINDERTENGERECHTES WASCHBECKEN

BB R 4040 LAB

0-100
CLASSIC WHITE

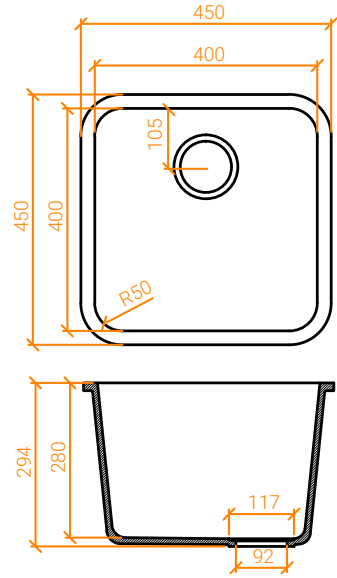

Kg 8 →| |← 450 450 294
 |← →| 400 400 280



BB R 5540 LAB

0-100
CLASSIC WHITE

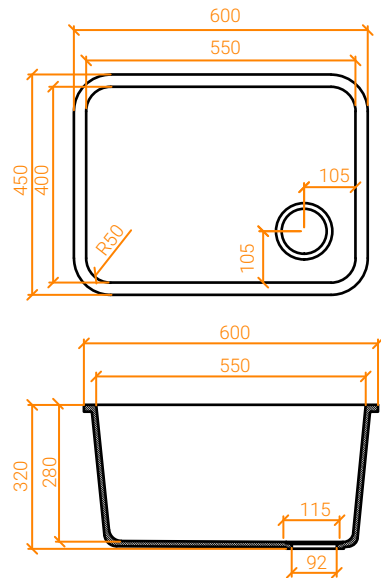

Kg 14 →| |← 450 600 320
 |← →| 400 550 280

BB R 617

0-100
CLASSIC WHITE

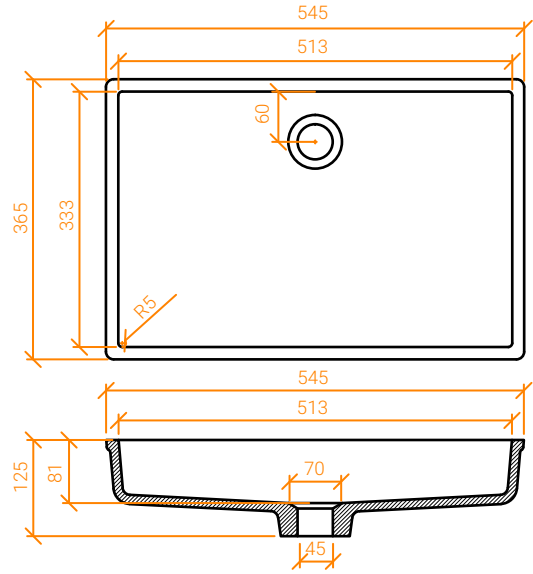

Kg 8



| | | |
|-----|-----|-----|
| 365 | 545 | 125 |
| 333 | 513 | 81 |



BB R 618

0-100
CLASSIC WHITE

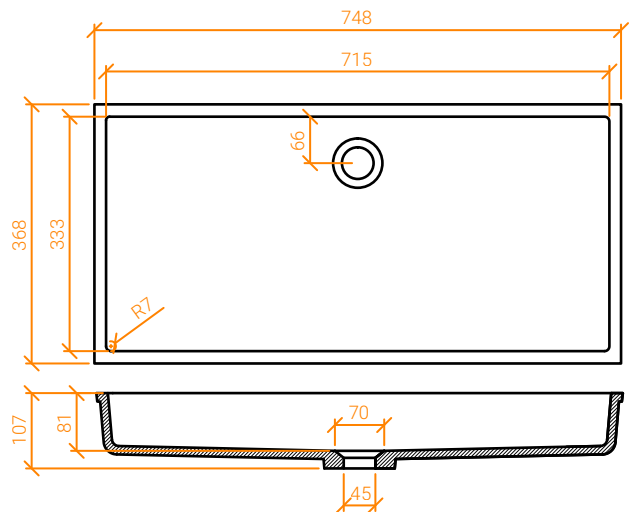

Kg 12



| | | |
|-----|-----|-----|
| 368 | 748 | 107 |
| 333 | 715 | 81 |

BB R 5029 PMR

0-100
CLASSIC WHITE

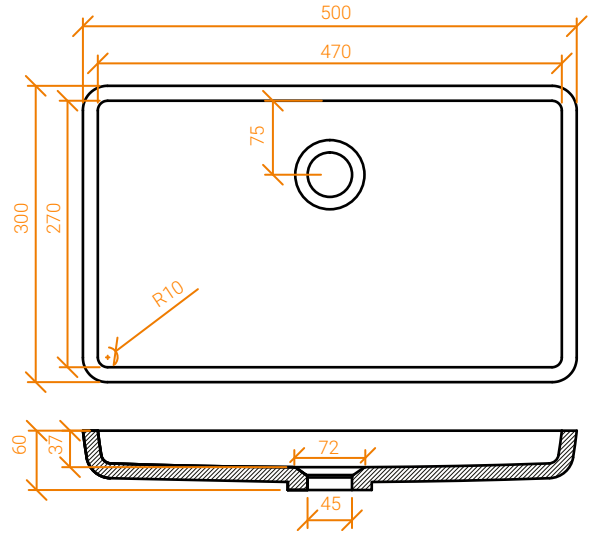

Kg 4



300 500
270 470

60
37



BB R 420 PMR

0-100
CLASSIC WHITE

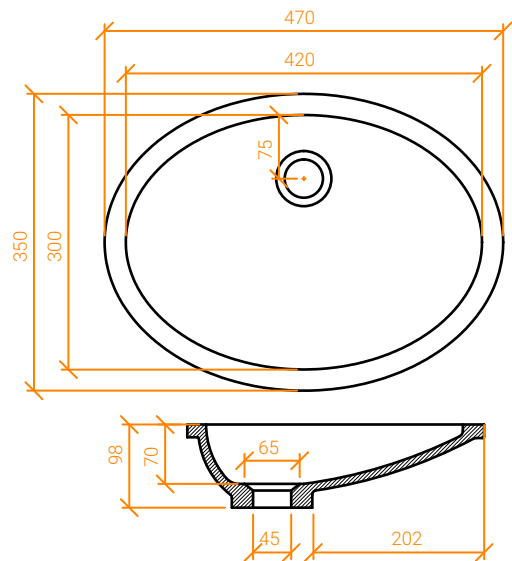

Kg 4



350 470
300 420

98
70

BB R 675 PMR

0-100
CLASSIC WHITE

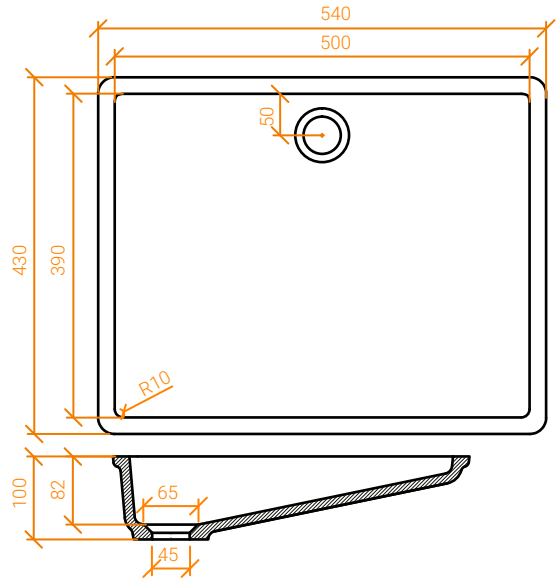

Kg 7



430
390

540
500

100
82



BB R 670 PMR

0-100
CLASSIC WHITE

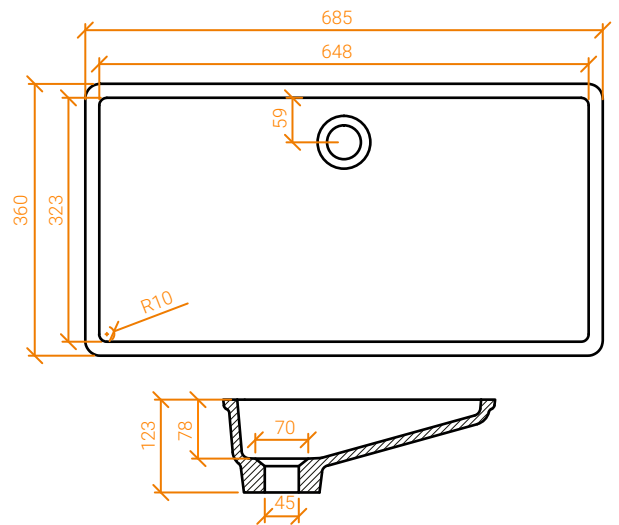

Kg 7



360
323

685
648

123
78

BER 6738 LB

0-100
CLASSIC WHITE

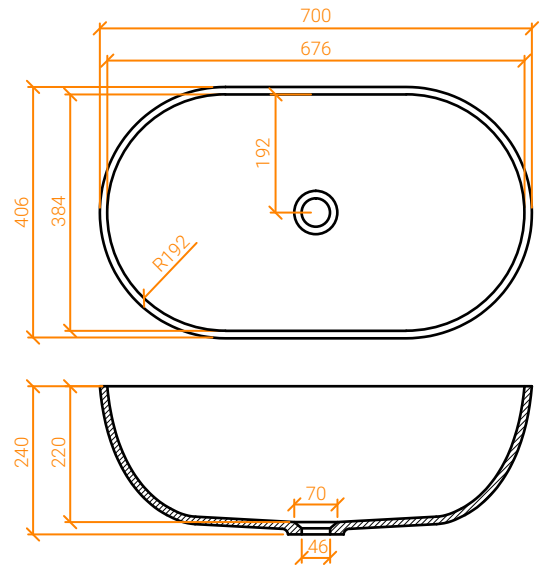

Kg 11



406

700

240



384

676

220

BER 6742 LB

0-100
CLASSIC WHITE

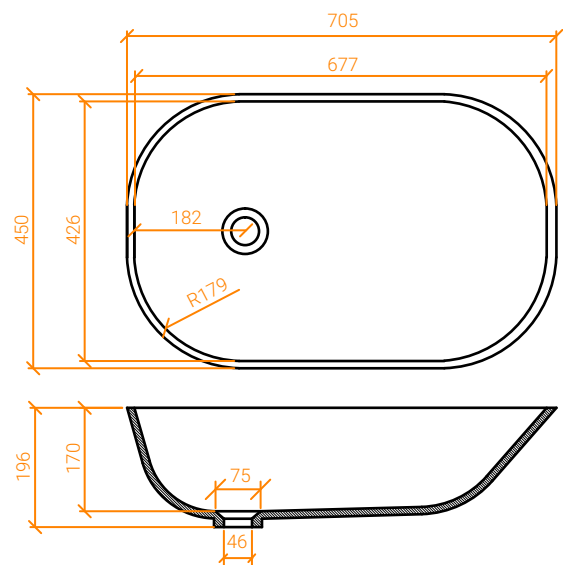

Kg 10



450

705

196



426

677

170

BB R 4051 W

0-100
CLASSIC WHITE

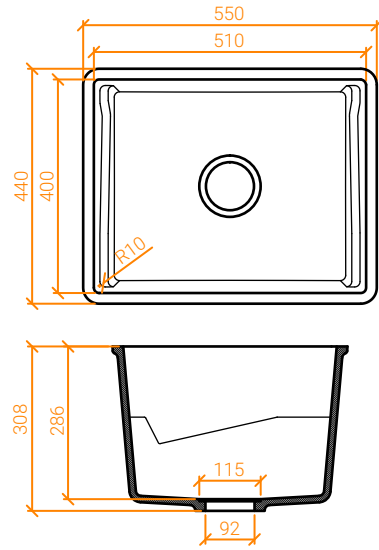

| | | | | | |
|-------|---|---|-----|-----|-----|
| Kg 15 | → | ← | 440 | 550 | 308 |
| | ← | → | 400 | 510 | 286 |



BER 1 SURG

0-100
CLASSIC WHITE

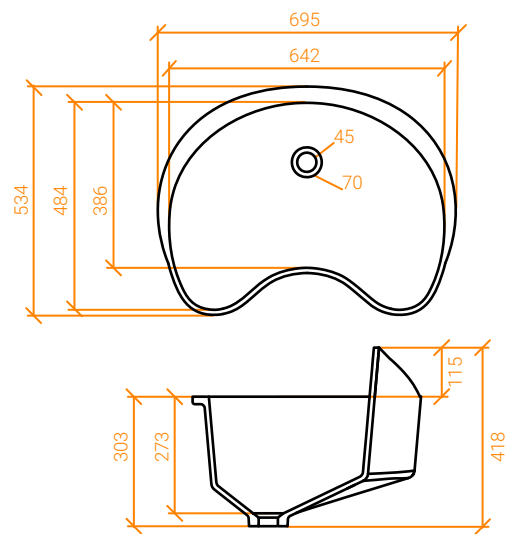

| | | | | | |
|-------|---|---|-----|-----|-----|
| Kg 15 | → | ← | 534 | 695 | 418 |
| | ← | → | 386 | 642 | 273 |

BER 2 SURG

0-100
CLASSIC WHITE

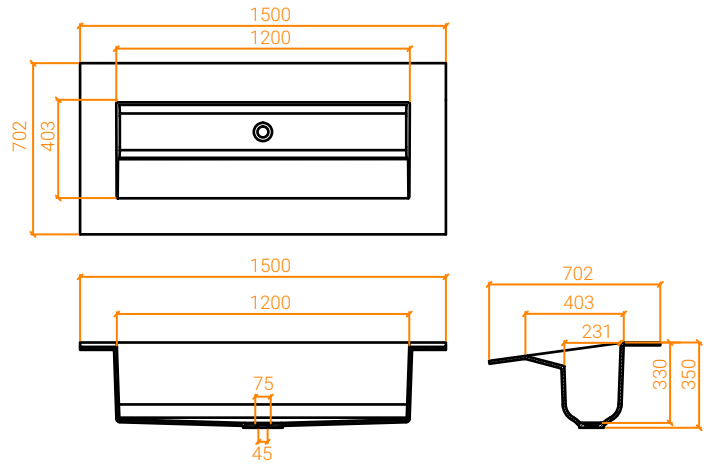

Kg 50



702 1500 350
403 1200 330



BER 3 SURG

0-100
CLASSIC WHITE

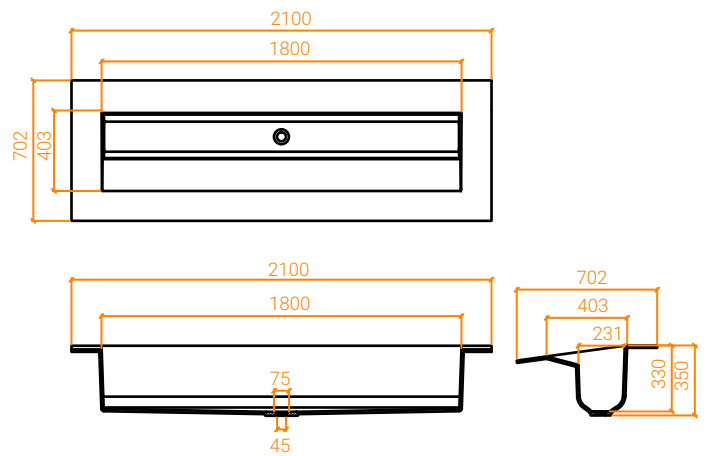

Kg 70



702 2100 350
403 1800 330

STAMPATI PERSONALIZZATI

CUSTOM SHAPE PRODUCTS PRODUCTOS INYECTADOS PERSONALIZADOS PRODUITS MOULÉS PERSONNALISÉS FORMTEIL-SONDERANFERTIGUNGEN

Così come per le lastre, è possibile realizzare prodotti stampati custom. A seguito dell'invio del disegno tecnico della forma desiderata, si effettuerà uno studio di fattibilità con relativa quotazione specifica. La produzione personalizzata di prodotti stampati è soggetta a specifici lotti minimi e richiede tempi di consegna di 8 - 10 settimane dall'approvazione del prototipo.

ESEMPI | EXAMPLES | EJEMPLOS | EXEMPLES | BEISPIELE

| | min. un. |
|--|----------|
| Lavello da cucina Kitchen Sink Fregadero de cocina Évier de cuisine Küchenspülen | 50 un. |
| Lavabo da bagno Bathroom washbowl Lavabo de baño Lavabo pour salle de bain Badezimmer Waschbecken | 50 un. |
| Vasca da bagno Bathub Bañera Baignoire Badewanne | 15 un. |

We can realise not only custom sheets, but also custom shape products. Once received the technical drawing of the shape product you would like to realise, we will carry out a feasibility study on it and send a specific price quotation. Custom productions for personalised shape products are subject to specific minimum order quantities and require an estimated delivery time of around 8-10 weeks, after the prototype approval.

De la misma manera que para las planchas personalizadas, pueden crear sus productos inyectados personalizados. Nos debe enviar un dibujo técnico de la forma que necesita, procedemos con un estudio de viabilidad y le comunicamos un presupuesto personalizado. La fabricación de formas personalizadas inyectadas está sujeta a mínimos y requiere 8 a 10 semanas de entrega a partir de la aprobación del prototipo.

De la même manière que pour les plaques sur mesure, vous pouvez créer vos produits injectés personnalisés. Pour procéder veuillez nous communiquer le dessin technique de la forme à atteindre, nous effectuons une étude de faisabilité et vous communiquons un devis personnalisé. A partir de la validation du dessin technique, 3 semaines plus transport sont nécessaires à la réalisation du prototype. La fabrication de forme injectée sur mesure est soumise à des minimas et nécessite un délai de livraison de 8 à 10 semaines à partir de l'approbation du prototype.

Wir sind in der Lage nicht nur Platten- sondern auch Formteil-Sonderanfertigungen herzustellen. Sobald wir die technische Zeichnung Ihres Wunsch-Formteiles erhalten haben, erstellen wir eine Durchführbarkeitsstudie darüber und senden Ihnen eine spezifische Preisangebot. Die Formteilen-Sonderanfertigungen unterliegen speziellen Mindestbestellmengen. Ab Zustimmung den Prototyp benötigen unsere Sonderanfertigungen eine Lieferzeit zwischen 8 und 10 Wochen.

COLLE, ACCESSORI E ATTREZZATURE

GLUES, ACCESSORIES AND EQUIPMENTS
COLAS, ACCESORIOS Y EQUIPOS
ADHÉSIFS, ACCESSOIRES ET ÉQUIPEMENT
KLEBER, ZUBEHÖRE UND AUSRÜSTUNG



SISTEMA INCOLLAGGIO

AHDESIVES FOR ACRYLIC STONE SHEETS AND SHAPES
COLAS POR PIEDRA ACRILICA Y PRODUCTOS INYECTADOS
ADHÉSIFS POUR PIERRE ACRYLIQUE ET PRODUITS MOULÉS
KLEBER FÜR ACRYLSTEIN UND FORMTEILE

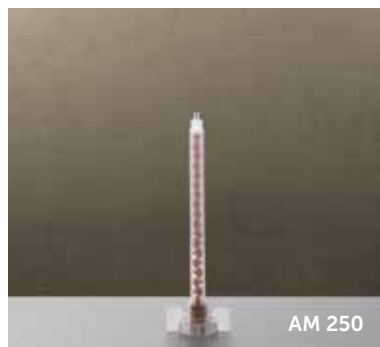
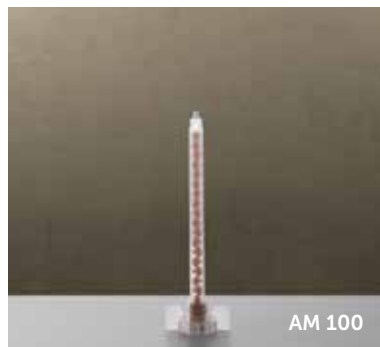

COLORI

COLOURS
COLORES
COULEURS
FARBEN

| ml | cod | sheet | ref. | box |
|-----|-------------------------|------------------------|--------|-------------------|
| 50 | AC 50 | 0-100 Classic White | * 2420 | 10 un. |
| 100 | AC 100 | 0-100 Classic White | * 2420 | 20 un. |
| 100 | AC 100 | 0-090 Igloo White | 3097 | 20 un. |
| 100 | AC 100 | 0-101 Old Cameo | 0310 | 20 un. |
| 100 | AC 100 | 0-110 Vanilla Ice | 3148 | 20 un. |
| 100 | AC 100 | 0-130 Traditional Bone | 3148 | 20 un. |
| 100 | AC 100 | 0-140 Butter | 2430 | 20 un. |
| 100 | AC 100 | 0-700 Coffee Brown | 3256 | 20 un. |
| 100 | AC 100 | 0-710 Terra Brown | 3345 | 20 un. |
| 100 | AC 100 | 0-810 Cloud Grey | 3272 | 20 un. |
| 100 | AC 100 | 0-830 Clay Grey | 3305 | NEW 20 un. |
| 100 | AC 100 | 0-840 Smart Grey | 3305 | 20 un. |
| 100 | AC 100 | 0-850 Concrete Grey | 3271 | 20 un. |
| 100 | AC 100 | 0-999 Night Dark | 0260 | 20 un. |
| 100 | AC 100 | 5-108 Victoria | 3006 | 20 un. |
| 100 | AC 100 | 5-159 Botticino | 3076 | 20 un. |
| 100 | AC 100 | 5-848 Travertino | 2377 | 20 un. |
| 100 | AC 100 | 5-118 Carrara White | A220 | NEW 20 un. |
| 100 | AC 100 | 5-818 Serpentino Grey | A242 | NEW 20 un. |
| 100 | AC 100 | 5-918 Marquina Black | A167 | NEW 20 un. |
| 250 | AC 250 | 0-100 Classic White | * 2420 | 20 un. |
| 500 | AC 500 | 0-100 Classic White | * 2420 | NEW 10 un. |
| 50 | AG 50 | | | 1 un |
| 100 | AG 100 | | | 1 un |
| 250 | AG 250 B | | | 1 un |
| 500 | AG 500 | | | NEW 1 un |
| | AM 50 100 250 500 | | | 20 un |

* Compatibili con
Suitable for
Compatible con
Compatible avec
Kompatibel und
0-100 Classic White | 0-011 Alpi White | 8-100 Classic White | 9-010 Artic White

MACCHINARI PER TERMOFORMATURA

THERMOFORMING MACHINERY
EQUIPO PARA TERMOCONFORMAR
ÉQUIPEMENT DE THERMOFORMAGE
TIEFZIEHMASCHINEN

Pressa idraulica

Hydraulic press

cod.

BPH080060

BPH130060

Forno ad aria calda

Hot air oven

cod.

BOE138096

BOE244096

BOE304096

Pressa a telo con forno ad aria calda integrato

Vacuum press with integrated hot air oven

cod.

BDT138106

BDT244106

BDT304106



SPECIFICHE TECNICHE

TECHNICAL SPECIFICATIONS
 ESPECIFICACIONES TÉCNICAS
 SPÉCIFICATIONS TECHNIQUES
 TECHNISCHE SPEZIFIKATIONEN



Prensa hidráulica | Presse hydraulique | Hydraulikpresse

| ← → | | Kg | Max °C | bar | KW | v | ~ | Hz | |
|------|-----|------|--------|-----|----|-----|---|-------|---|
| 800 | 600 | 805 | | 200 | 3 | 380 | 3 | 50/60 | |
| 1300 | 600 | 1310 | | 200 | 4 | 380 | 3 | 50/60 |  |

Horno de convección | Four à convection | Heißluftofen

| ← → | | Kg | Max °C | t/m ² | KW | v | ~ | Hz | |
|------|-----|-----|--------|------------------|----|-----|---|-------|---|
| 1380 | 960 | 635 | 190 | | 17 | 380 | 3 | 50/60 | |
| 2440 | 960 | 690 | 190 | | 17 | 380 | 3 | 50/60 |  |
| 3040 | 960 | 750 | 190 | | 17 | 380 | 3 | 50/60 |  |

Horno de convección y prensa de membrana combinada | Four a convection et presse a membrane combiné | Vakuumpresse mit integriertem Heißluftofen

| ← → | | Kg | Max °C | t/m ² | KW | v | ~ | Hz | |
|------|------|------|--------|------------------|----|---------|---|-------|---|
| 1380 | 1060 | 890 | 190 | 9,5 | 11 | 220/400 | 3 | 50/60 | |
| 2440 | 1060 | 970 | 190 | 9,5 | 19 | 220/400 | 3 | 50/60 |  |
| 3040 | 1060 | 1060 | 190 | 9,5 | 19 | 220/400 | 3 | 50/60 |  |



Su richiesta | On request | A petición | Sur demande | Auf Anfrage

ACCESSORI CUCINA

KITCHEN ACCESSORIES
 ACCESORIOS POR COCINA
 ACCESSOIRES POUR CUISINE
 KÜCHENZUBEHÖRE



KTCHG001



KTCHT003



KTCHG002



BTCL 500

cod.

| | | mm | mm | mm |
|------------------|---|-----|-----|----|
| KTCHG001* | Gocciolatoio coprilavello fresato Removable perforated drainboard covering the kitchen sink Escuridor fresado para fregadero de cocina Egouttoir perforé amovible recouvrant l'évier de cuisine Gelochte Abtropffläche über die Spülbeckenlänge verschiebbar | 430 | 295 | 9 |
| KTCHG002* | Gocciolatoio coprilavello forato Removable perforated drainboard covering the kitchen sink Escuridor perforado para fregadero de cocina Egouttoir perforé amovible recouvrant l'évier de cuisine Gelochte Abtropffläche über die Spülbeckenlänge verschiebbar | 430 | 295 | 9 |
| KTCHT003* | Tagliere coprilavello Removable cutting board covering the kitchen sink Plancha de corte para fregaderos de cocina Planche à découper amovible recouvrant l'évier de cuisine Schneidebrett über die Spülbeckenlänge verschiebbar | 430 | 295 | 9 |

BTCL 500ml

Per un'azione di pulizia facile e rapida, elimina velocemente ed in profondità tutto lo sporco, anche il più ostinato. Soluzione detergente alcalina concentrata a base di sali inorganici. Bassa schiumogenità.
 For a quick and easy cleaning action, it eliminates all the dirt quickly and thoroughly, and even the most stubborn ones. The concentrated alkaline detergent solution based on inorganic salts. Low foaming.
 Para una acción de limpieza rápida y fácil, elimina toda la suciedad rápida y completamente, e incluso las más difíciles. La solución concentrada de detergente alcalino a base de sales inorgánicas. Baja espuma.
 Pour une action de nettoyage rapide et facile, il élimine toute la saleté rapidement et à fond, même les plus tenaces. La solution détergente alcaline concentrée à base de sels inorganiques. Faible moussant.
 Für eine schnelle und einfache Reinigung beseitigt es alle Verschmutzungen schnell und gründlich und sogar die hartnäckigsten.
 Die konzentrierte alkalische Reinigungslösung basiert auf anorganischen Salzen. Schaumarm

* Compatibili con BS 3440 | BS 4040 | BS 4540 | BS 5340 | BS 7040
 Suitable for BS 4040 R | BS 5340 R
 Compatible con BB R 4040 LAB | BB R 5540 LAB
 Kompatibel und

ACCESSORI CUCINA E PROFESSIONALI

KITCHEN AND PROFESSIONAL ACCESSORIES
 ACCESORIOS DE COCINA Y PROFESIONALES
 ACCESSOIRES POUR LA CUISINE ET PROFESSIONNELS
 KÜCHE UND PROFESSIONELLES ZUBEHÖR



COVER001



KIT1V1TPS



KIT2V1TPS



12000B



12001



CLRE

cod.

COVER001

Tappo copripiletta in BETACRYL® 0-100 Classic White compatibile con KIT1V1TPS e KIT2V1TPS
 Plug drain cover in BETACRYL® 0-100 Classic White, compatible with KIT1V1TPS and KIT2V1TPS
 Tapa de desagüe en BETACRYL®, color 0-100 Classic White, y compatible con KIT1V1TPS y KIT2V1TPS
 Cache bonde en BETACRYL®, couleur 0-100 Classic White, compatible avec KIT1V1TPS et KIT2V1TPS
 Platte-Ventilstopfen aus BETACRYL®, 0-100 Classic White, mit dazu passend KIT1V1TPS und KIT2V1TPS

KIT1V1TPS

Kit piletta completa con raccordo troppo pieno e sifone salva-spazio 1 via
 Complete waste set supplied with overflow and space-saving siphon for single bowl sinks
 Desagüe completo con rebosadero y sifón salva espacio para 1 fregadero
 Vidage complet avec trop plein et tubulure gain de place pour éviers 1 bac
 Ablauf-Set mit raumsparendem Einzelspülsiphon und Ablauf-Verbindung

KIT2V1TPS

Kit piletta completa con raccordo troppo pieno e sifone salva-spazio 2 vie
 Complete waste set supplied with overflow and space-saving siphon for double bowl sinks
 Desagüe completo con rebosadero y sifón salva espacio para 2 fregadero
 Vidage complet avec trop plein et tubulure gain de place pour éviers 2 bacs
 Ablauf-Set mit raumsparendem Doppelspülsiphon und Ablauf-Verbindung

12000B

Nastro isolante in fibra ceramica - 15mm x 10m
 Ceramic fiber tape - 15mm x 10m
 Cinta en fibra de Ceramica - 15mm x 10m
 Bande en fibre céramique - 15mm x 10m
 Keramikfaserband - 15mm x 10m

12001

Nastro riflettente in alluminio - 50mm x 50m
 Aluminium foil tape - 50mm x 50m
 Cinta de aluminio - 50mm x 50m
 Bande en aluminium - 50mm x 50m
 Aluminiumband - 50mm x 50m

CLRE

Collettore per troppo pieno
 Overflow
 Rebosadero
 Trop plein
 Überlauf

ACCESSORI BAGNO

BATHROOM ACCESSORIES
ACCESORIOS POR BAÑO
ACCESSOIRES POUR SALLE DE BAIN
BADEZIMMER ZUBEHÖRE



COVER 002



KITPSB03



KITPSB04



UD 22551



WA 11195



WF 21195

cod.

COVER002

Copripiletta in BETACRYL® 0-100 Classic White compatibile con piletta UD 22551 in modalità scarico libero
Drain cover in BETACRYL®, with 0-100 Classic White compatible, free flow version, with drain UD 22551
Tapa de desagüe en BETACRYL®, color 0-100 Classic White, con salida libre, y compatible con UD 22551
Cache Bonde en BETACRYL®, couleur 0-100 Classic White, à écoulement libre, compatible avec bonde d'évacuation UD 22551
Freie Ablaufgarnitur mit Ablaufstopfen aus BETACRYL®, mit dazu passend 0-100 Classic White und UD 22551

KITPSB03

Kit troppo pieno per lavabo con tubo corrugato con ghiera circolare cromata
Overflow kit with flexible pipe for washbowl with chromed circular ring
Kit por desagüe de fregadero con tubo flexible y anillo circular cromado
Vidage pour lavabos avec tube flexible et anneau circulaire chromé
Ablaufgarnitur-Kit, flexibler Überlaufschlauch für Waschbecken und verchromter Kreisring

KITPSB04

Kit troppo pieno per lavabo con tubo corrugato e collettore per troppo pieno
Overflow kit with flexible pipe for washbowl and overflow
Kit por desagüe de fregadero con tubo flexible y rebosadero
Vidage pour lavabos avec tube flexible avec trop plein
Ablaufgarnitur-Kit, flexibler Überlaufschlauch für Waschbecken und überlauf

UD22551

Scarico universale con tappo clic clac per lavabo
Universal basin waste, waste up&down plug
Desagüe universal por lavabos sistema de apertura clic - clac
Vidage universel pour lavabos, système d'ouverture-fermeture clic-clac
Universal Waschtisch-Ablaufgarnitur mit up&down System

WA11195

Scarico universale con tappo clic clac per lavabo
Universal basin waste, waste up&down plug
Desagüe universal por lavabos sistema de apertura clic - clac
Vidage universel pour lavabo, système d'ouverture-fermeture clic-clac
Universal Waschtisch-Ablaufgarnitur mit up&down System

WF21195

Scarico libero universale per lavabo
Universal basin waste
Desagüe universal por lavabos
Vidage universel pour lavabo
Universal Waschtisch-Ablaufgarnitur

ACCESSORI VASCHE DA BAGNO

BATHTUBS ACCESSORIES
ACCESORIOS POR BAÑERA
ACCESSOIRES POUR BAGNOIRES
BADEWANNEN ZUBEHÖRE

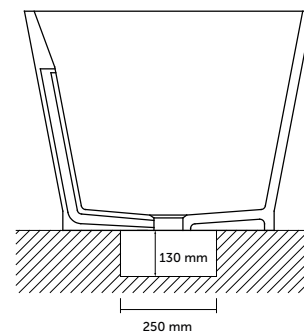
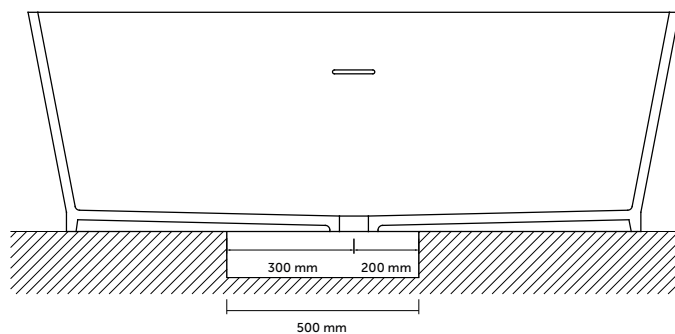

UD 37051



AS 076



U3 S 36 00 51

cod.

UD37051

Scarico per vasca da bagno con tappo clic clac
Waste up&down plug for bathtub
Desagüe universal por bañera, sistema de apertura up & down
Vidage universel pour baignoires avec système d'ouverture-fermeture clic-clac
Ab/und Überlaufgarnitur für Badewanne mit Up&down System

AS 076

Sifone snodato in PEH
PEH swivel siphon
Sifón orientable en PEH
Siphon amovible en PEH
Geruchverschluss mit Überwurf

U3 S 36 00 51

Scarico per vasca da bagno con kit troppo pieno integrato
Waste kit with overflow for bathtubs
Kit desague integrado por bañera
Vidage avec trop plein intégré pour baignoire
Ablaufgarnitur mit Überlaufschlauch für Badewannen

USO E MANUTENZIONE

USE AND CARE CONSEJOS DE MANTENIMIENTO CONSEILS D'ENTRETIEN PFLEGETIPPS

BETACRYL® Pure Acrylic Stone offre un'ottima resistenza alle sollecitazioni chimiche e meccaniche comuni a varie applicazioni, domestiche o professionali.

In ogni caso, come per tutti i materiali, è necessaria una regolare cura nella pulizia della superficie ed una periodica manutenzione.

Bastano pochi semplici accorgimenti ed il vostro piano e le vostre vasche in BETACRYL® resteranno in condizioni perfette come il giorno in cui li avete acquistati.

BETACRYL® Pure Acrylic Stone offers an excellent resistance to chemicals and mechanical stress in various applications, both domestic and professional.

In any case, as for other materials, is necessary to have a regular care, cleaning and periodic maintenance of the surface.

Here you will find few simple steps in order to maintain your countertop BETACRYL® in perfect conditions as the first day of use.

BETACRYL® Pure Acrylic Stone también ofrece una excelente resistencia a los químicos y a los esfuerzos mecánicos comunes a varias aplicaciones, domésticos o profesionales.

En cualquier caso, como para todos los materiales, es necesario prestar atención a la limpieza de la superficie y al mantenimiento periódico.

Sólo unos pocos pasos simples y su encimera BETACRYL® se mantendrá en perfecto estado como el día que la compró.

BETACRYL® Pure Acrylic Stone offre une excellente résistance aux produits chimiques et aux contraintes mécaniques aussi bien dans les applications domestiques que professionnelles.

Dans tous les cas, comme pour tous les matériaux, il est nécessaire de prêter attention au nettoyage de la surface et d'effectuer un entretien régulier.

Voilà quelques étapes simples pour maintenir votre comptoir BETACRYL® comme au premier jour.

BETACRYL® Pure Acrylic Stone bietet eine hervorragende Beständigkeit gegenüber chemischen und mechanischen Belastungen und ist sowohl für Private Haushalte als auch berufliche Anwendungen geeignet.

Auf jeden Fall, wie für alle jedes Material, ist eine regelmäßige Pflege, Reinigung und Instandhaltung der Oberfläche erforderlich.

Hiersind Nur wenige Klugheiten, und ihre BETACRYL® Arbeitoberflächen und Becken werden wie neu bleiben, als ob Sie sie eben gekauft hätten.

URTI E GRAFFI

SHOCKS AND SCRATCHES
GOLPES Y RASGUÑOS
RAYURES ET FISSURES
DIE BEULEN UND KRATZER

BETACRYL® resiste in maniera eccellente alle comuni sollecitazioni meccaniche. Consigliamo comunque di non utilizzarlo come piano da taglio, potrebbe scalfirsi! Per scalfiture leggere, trattare il piano come nel caso di opacizzazione da calore. Nel caso di solchi molto profondi, rivolgersi al proprio rivenditore che, come nel caso di spaccature, si attiverà per far ripristinare perfettamente il vostro piano. La migliore caratteristica di BETACRYL® è di essere sempre riparabile.

BETACRYL® has an excellent resistance to common mechanical stresses. However we suggest that you to avoid using your countertop as a chopping board, since it could damage it. For any scratches on the surface you can treat the surface in the same way as for stains. In the case of very deep ruts, as well as in case of cracks, contact your dealer, it will help you to restore your BETACRYL® countertop in the best way. The best feature of BETACRYL® is its whole restorability.

BETACRYL® resiste excelentemente a la tensión mecánica común. Sin embargo, le sugerimos que no corte directamente encima de su encimera, porque se puede rayar! Para ranuras leves, tratar la encimera como en el caso de tratamiento por exposición al calor. En el caso de daños muy profundos, póngase en contacto con su distribuidor, como en el caso de grietas, para que se restaurará completamente su placa. La mejor característica de BETACRYL® es que siempre puede ser reparado.

BETACRYL® résiste très bien au stress mécanique. Toutefois, nous vous suggérons de ne pas couper directement sur la surface, car vous pouvez la rayer! Pour les rayures mineures, traiter la surface comme dans le cas de l'exposition à un dommage thermique. Dans le cas de dommage très profond, contactez votre revendeur, afin d'effectuer les réparations nécessaire à la restauration complète de la surface. La meilleure caractéristique de BETACRYL® est qu'il peut être toujours réparé.

BETACRYL® hält normale mechanische Belastungen aus. Wir empfehlen jedoch nicht auf der Arbeitsfläche zu schneiden, weil diese verkratzen könnte. Bei leichten Kratzern wird die Arbeitsfläche wie im Falle von heißen Gegenständen behandelt. Im Falle von tiefen Kratzern und Rissen wenden Sie sich an Ihren Fachhändler. Es wird ihnen den Schaden wieder perfekt beheben. Die beste Eigenschaft von BETACRYL® ist, dass es reparabel ist.

MACCHIE

STAINS MANCHAS TÂCHES FLECKEN

BETACRYL® non è poroso e quindi non assorbe alcun liquido col quale possa venire a contatto: ogni macchia può essere solo superficiale.

In caso di macchie non ostinate, trattare il piano con un panno, acqua ed un normale detergente per uso domestico.

Nel caso in cui le macchie fossero più tenaci, trattare la superficie con una spugna Scotchbrite® ed un detergente cremoso abrasivo, effettuando un movimento circolare.

Per eliminare le incrostazioni di calcare usare la spugna abrasiva, aceto o detergente all'aceto.

Le macchie causate da sigaretta si eliminano con uno strofinaccio e del detergente abrasivo.

E' buona norma una volta alla settimana riempire le vasche con acqua calda e 1-2 cucchiaini di candeggina liquida. Lasciare agire per qualche ora e poi sciacquare ed asciugare.

Non usare detergenti grassi o a base di cera per evitare che si formi una patina sulla superficie della lastra.

Evitare il contatto con sostanze chimiche caustiche, solventi, soluzioni di cloruro di metile, acetone e liquidi per la pulizia dei forni e metalli; qualora ciò accada risciacquare prontamente il piano con abbondante acqua saponata ed asciugare la superficie con un panno morbido.

BETACRYL® is a non-porous material and therefore doesn't absorb the liquids with which it may come into contact. Therefore stains can be only superficial.

In case of easy to remove stains, treat the surface with a cloth, water and ordinary household detergent.

In case of stubborn stains, treat the surface with a scouring pad as a Scotchbrite® and an abrasive creamy cleanser, making circular movements.

To remove limestone build-ups, use a scouring pad together with some vinegar or anti-limestone products.

Stains caused by cigarette can be removed with a cloth and a mild abrasive creamy cleanser.

It's a good practice, once a week, to fill the sink bowls with hot water and 1-2 teaspoons of liquid bleach. Leave it for a few hours and then rinse it and dry it.

Do not use fat or wax-based detergent in order to avoid the formation of a patina on the surface.

Avoid contact with caustic chemicals, solvents, solution of methyl chloride, acetone and liquid products for ovens and hobs cleaning. In case it occurs, rinse the surface quickly with soap and water and dry it with a soft cloth.

BETACRYL® no es poroso, y por lo tanto no absorbe el líquido con el que podrá ponerse en contacto: cada mancha puede ser sólo superficial.

En caso de manchas leves, tratar la superficie con un paño, agua y detergente normal para uso domestico.

En el caso de que las manchas sean más tenaces, tratar la superficie con una esponja Scotchbrite® (estropajo) y un detergente cremoso abrasivo, aplicándolo con un movimiento circular.

Para eliminar la cal usar esponjas abrasivas, vinagre o limpiador de vinagre.

Las manchas causadas por el cigarrillo se quitan con un estropajo y un detergente abrasivo.

Es una buena idea llenar las pilas una vez por semana con agua caliente y 1-2 cucharaditas de cloro líquido. Deja por unas horas y luego enjuague y seque.

No utilizar detergentes grasos o a base de cera para evitar deslaminamientos en la superficie de la placa.

Evitar el contacto con productos químicos cáusticos, solventes, soluciones de cloruro de metilo, acetona y líquidos para la limpieza de hornos y metales, en caso de limpieza rápida, enjuague la encimera con abundante agua y jabón y secar la superficie con un paño suave.

BETACRYL® est non poreux, donc il n'absorbera pas les liquides avec lesquels il entrerait en contact: toutes les taches ne seront que superficielles.

En cas de tâches mineures, traitez la surface avec un détergent standard pour l'usage domestique et rincez abondamment à l'eau.

Dans le cas de tâches tenaces, traitez la surface avec une éponge Scotchbrite® et un détergent abrasif crémeux, appliquez des mouvements circulaires, puis rincez abondamment à l'eau.

Pour supprimer le calcaire qui se serait déposé en surface, utilisez une éponge abrasive, du vinaigre ou un nettoyeur à base de vinaigre.

Les tâches causées par le tabac sont enlevées avec une éponge et un abrasif doux.

Il est conseillé de remplir votre évier une fois par semaine avec de l'eau chaude et 1-2 cuillères à café de chlore liquide. Laisser reposer pendant quelques heures, puis rincez et séchez.

N'utilisez pas de détergents gras ou de cire sur la surface.

Eviter le contact avec des produits chimiques corrosifs, solvants, solutions de chlorure de méthyle, l'acétone et liquides pour le nettoyage des fours et des métaux. Pour un nettoyage rapide, rincer la surface avec de l'eau et du savon et sécher la surface avec un chiffon doux.

BETACRYL® ist nicht porös und absorbiert daher keine Flüssigkeiten mit denen es in Kontakt kommt. Jeder Fleck ist nur oberflächlich. Im Falle von nicht zähen Flecken behandeln Sie die Arbeitsfläche mit einem Tuch, Wasser und normalem Haushaltsreiniger.

Bei zähen Flecken benutzen Sie einen Scotch Brite® Schwamm, ein cremiges Scheuermittel und entfernen den Fleck mit kreisförmigen Bewegungen.

Um Kalk zu entfernen, verwenden Sie einen Scheuerschwamm, Essig oder Essigreiniger. Durch Zigaretten verursachte Flecken werden mit einem Tuch und Scheuermittel entfernt.

Einmal in der Woche füllen Sie das Becken mit heissem Wasser und 1-2 Teelöffel Bleichmittel.

Lassen Sie das Mittel für ein paar Stunden wirken, danach spülen und trocknen Sie das Becken.

Verwenden Sie keine fettigen oder wachshaltigen Reinigungsmittel, damit sich kein Belag auf der Oberfläche bildet.

Vermeiden Sie den Kontakt mit ätzenden Chemikalien, Lösungsmitteln, Methylchlorid, Azeton und Flüssigkeiten zur Reinigung von Backöfen und Metallen. Sollte dies vorkommen, spülen Sie umgehend die Arbeitsfläche mit viel Seifenwasser und trocknen Sie mit einem weichen Tuch nach.

ALTE TEMPERATURE

HIGH TEMPERATURES ALTAS TEMPERATURAS TEMPÉRATURES ÉLEVÉES HOHE TEMPERATUR

BETACRYL® resiste al calore molto meglio di altri materiali da rivestimento, tuttavia, appoggiare pentole, caffettiere o qualsiasi altro oggetto molto caldo direttamente sul piano, potrebbe causare danni alla superficie; consigliamo quindi di utilizzare sempre sottopentola o barrette in acciaio paracalore.

Se versate liquidi bollenti direttamente nel lavello, è consigliabile aprire il rubinetto dell'acqua fredda. Inoltre, è sempre buona norma utilizzare pentole della dimensione adeguata al bruciatore e collocarle sempre al suo centro; se i bordi della pentola fuoriescono dal piano cottura, la superficie circostante potrebbe essere danneggiata.

Nel caso in cui un oggetto particolarmente caldo, o una sigaretta accesa, restasse a contatto diretto con la superficie per un lungo periodo, potrebbe verificarsi una perdita di lucentezza superficiale.

Trattare la zona opacizzata con una spugnetta Scotchbrite® ed un detergente cremoso abrasivo, ripassare la stessa zona con un panno ed una crema lucidante tipo Polish effettuando un movimento circolare. La superficie riprenderà la sua brillantezza, perchè BETACRYL® non è poroso ed è omogeneo in tutto il suo spessore.

BETACRYL® resists to high temperatures better than other coating materials. However, placing hot pots directly on the surface may damage it. Therefore we recommend to always use a trivet.

If you need to pour hot liquids directly into the sink bowls, do open the cold water tap too.

Furthermore, always use appropriate size pots on hob burners and place them always at the center. Should the pot come out of the hob, the surrounding surface may lose its glossy aspect.

Treat the damaged area with a scouring pad as a Scotchbrite® and a mild abrasive cream and polish it with circular movements until the surface regains its brilliance.

BETACRYL® is non-porous and homogeneous throughout its thickness.

BETACRYL® soporta el calor mejor que otros materiales de revestimiento, sin embargo, las ollas, las cafeteras o cualquier otro objeto muy caliente puesto directamente sobre el material, podría causar daños a la superficie, le recomendamos que utilice siempre las barras de soporte o protectores de calor de acero.

Si se vierte líquido en ebullición directamente en el fregadero, usted debe abrir el grifo de agua fría. Además, siempre es una buena práctica utilizar las ollas de tamaño apropiado para el quemador y colocarlas siempre en el centro, si los bordes sobresalgan del molde de la placa, la superficie que los rodea podría estar dañada.

En el caso en que un objeto es muy caliente o un cigarrillo encendido permanece en contacto directo con la superficie para un período largo, puede haber una pérdida de brillo superficial.

Trate la zona afectada con una esponja Scotchbrite® y un detergente cremoso abrasivo, repasa la misma área con un paño y un crema pulido como Polish, realizando un movimiento circular. La superficie recuperará su brillo, porque BETACRYL® no es poroso y es homogéneo en todo su espesor.

BETACRYL® résiste à la chaleur mieux que d'autres matériaux de revêtement. Cependant, des casseroles ou tout autre objet chaud placé directement sur la surface, pourrait y causer des dommages. Donc nous vous recommandons de toujours utiliser les barres de soutien comme bouclier thermique.

Si vous versez un liquide bouillant directement dans l'évier, vous devez ouvrir le robinet d'eau froide au préalable. En outre, il est toujours recommandé d'utiliser des casseroles de tailles appropriées pour le brûleur et les placer toujours au centre afin de ne pas endommager la surface au bord de la plaque de cuisson.

Dans le cas où un objet est trop chaud ou une cigarette allumée reste en contact direct avec la surface pendant une longue période, il peut y avoir une perte de brillance de surface.

Dans ce cas, afin de récupérer la brillance de la surface, traiter la zone affectée avec une éponge Scotchbrite® et une crème abrasive douce, rincez abondamment à l'eau puis séchez et polissez avec un chiffon sec et une crème à polir le tous dans un mouvement circulaire.

BETACRYL® est non poreux et homogène dans toute son épaisseur.

BETACRYL® widersteht der Hitze viel besser als andere Beschichtungsmaterialien. Trotzdem sollte man Kochtöpfe - Mokkaeschinen oder sonstige sehr heiße Gegenstände nicht direkt auf die Arbeitsfläche stellen. Diese könnten kleinere Schäden auf der Oberfläche verursachen. Wir empfehlen immer Untersetzer zu verwenden.

Wenn Sie siedende Flüssigkeit ins Becken giessen, ist es empfehlenswert den Kaltwasserhahn zu öffnen.

Generell ist man gut damit beraten, zur Brennergröße passende Töpfe zu verwenden. Die Töpfe sollten in die Mitte des Brenners gestellt werden, wenn die Ränder der Pfanne über das Kochfeld hinausragen, kann die umgebende Oberfläche beschädigt werden.

Sollte ein heisser Gegenstand oder eine angezündete Zigarette für eine längere Zeit in Kontakt mit der Oberfläche kommen, könnte die Oberfläche an Glanz verlieren. Behandeln Sie den matten Bereich zuerst mit einem Scotch Brite® Schwamm und einem cremigen Scheuermittel und danach mit einem Tuch und einer Glanzcreme (Polish) mit kreisenden Bewegungen. Die Oberfläche wird so wieder zu ihrem Glanz kommen, weil BETACRYL® nicht porös und in seiner gesamten Plattenstärke homogen ist.

INDICAZIONI GENERALI

GENERAL INDICATION INDICACIONES GENERALES INDICATIONS GÉNÉRALES ALLGEMEINE INDIKATIONEN

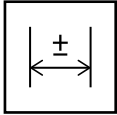

Le misure dei prodotti stampati sono soggette alle tolleranze indicate nel relativo allegato tecnico.

The sizes of the printed products are subject to the tolerances indicated in the relative technical annex/attachment.
Los tamaños de los productos inyectados están sujetos a las tolerancias indicadas en el anexo técnico correspondiente
Les tailles des produits injectés sont soumises aux tolérances indiquées dans l'annexe technique correspondante
Die Maße der Druckerzeugnisse unterliegen den Toleranzen, die im entsprechenden technischen Anhang angegeben sind

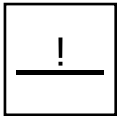

Le tonalità più scure non sono consigliate per applicazioni che prevedono l'uso intensivo della superficie.

The darkest colour shades are not recommended for applications involving a heavy-duty use of the surface.
Los colores oscuros no se recomiendan para aplicaciones que requieren un uso intenso de la superficie sólida.
Les nuances de couleur foncées ne sont pas recommandées pour des applications qui impliquent l'utilisation intensive de la surface.
Eine Anwendung der dunkelsten Farbtöne wird bei Oberflächen, welche sich durch intensive Nutzung hervorheben, nicht empfohlen.

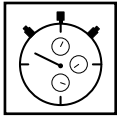

Trasporti urgenti e per destinazioni particolari verranno quotati separatamente su richiesta.

Urgent transport and for peculiar destinations will be quoted separately by request.
Transporte urgente y para destinos particulares se cotiza por separado y bajo petición.
Les transports urgent et pour des destinations particulières seront indiqués séparément et sur demande.
Dringender Transport und für besonderen Zielen wird auf Anfrage separat angegeben.



Per acquisti inferiori al pallet completo non è garantita l'appartenenza delle lastre allo stesso lotto a meno di specifica richiesta scritta.

For purchases lower than the full pallet it is not guaranteed that the sheets belong to the same production batch unless a specific written request.
Para compras inferiores a la paleta completa, no se garantiza que las placas pertenezcan al mismo lote de producción a menos que haya una solicitud escrita específica.
Pour les achats inférieurs à la palette complète, il n'est pas garanti que les plaques appartiennent au même lot de production sauf demande écrite spécifique.
Bei Käufen, die niedriger als die komplette Palette sind, ist nicht garantiert, dass die Platten zu derselben Produktionscharge gehören, es sei denn, es handelt sich um eine spezielle schriftliche Anfrage.

LEGENDA

LEGEND | LEYENDA | LÉGENDE | LEGENDE



Su richiesta
On request
A petición
Sur demande
Auf Anfrage

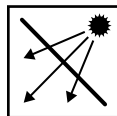

Traslucente
Translucent
Translúcido
Translucide
Transluzent



Articolo per pediatria
Item for paediatric use
Artículo para instalaciones pediátricas
Article à usage pédiatrique
Artikel für die pädiatrische Verwendung



Articolo per persone a mobilità ridotta
Item intended for persons with reduced mobility
Artículo para personas de movilidad reducida
Produit pour personnes à mobilité réduite
Artikel für in ihrer Mobilität eingeschränkte Personen

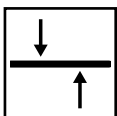

Modello da appoggio integrabile previa rettifica del bordo.
Freestanding model, which may be integrated after edge rectification.
Modelo de encimera, que puede integrarse después de la rectificación de bordes.
Modèle à poser, qui peut être intégré après la rectification des bords.
Arbeitsplattenmodell, das nach der Kantenrektifikation integriert werden kann.

INDICE

INDEX
ÍNDICE
INDICE
INDEX

| | | | |
|----|---|----|---|
| 3 | UNA FRONTIERA DIMENSIONALE D'ECCELLENZA AN EXCELLENT RANGE OF DIMENSIONS UNA GAMA DE TAMAÑOS DE EXCELENCIA UNE GAMME DE TAILLES D'EXCELLENCE EINE HERVORRAGENDE AUSWAHL AN GRÖSSEN | 32 | LAVELLI DA CUCINA KITCHEN SINKS FREGADEROS DE COCINA EVIERS DE CUISINE KÜCHENSÜPPE |
| 4 | BETACRYL PURE ACRYLIC STONE | 39 | LAVABI DA BAGNO INTEGRABILI BUILTIN WASHBOWLS FREGADEROS INTEGRADOS LAVABOS INTÉGRÉS EINGebaute WAschBECKEN |
| 5 | NOVITÀ NEWS | 52 | LAVABI DA BAGNO DA APPOGGIO FREESTANDING BATHROOM BASINS LAVABOS DE BAÑO LAVABOS POUR SALLE DE BAIN À POSER BADEZIMMER WAschBECKEN |
| 6 | BETAFLEX EXTRA FLEXIBLE ACRYLIC STONE | 64 | VASCHE DA BAGNO BATHTUBS BAÑERAS BAIGNOIRES BADEWANNEN |
| 10 | BETALITE MODIFIED ACRYLIC SURFACE | 70 | LAVABI PROFESSIONALI E PER DISABILI PROFESSIONAL BASINS AND FOR DISABLED LAVABOS PROFESIONALES Y POR DESECAPACITADOS LAVABOS PROFESSIONNELS ET PMR PROFESSIONELLE UND BEHINDERTENGERECHTES WAschBECKEN |
| 12 | DIMENSIONI E SPESSORI DIMENSIONS DIMENSIONES Y ESPESORES DIMENSIONS ET ÉPAISSEURS MAßE UND STÄRKEN | 78 | STAMPATI PERSONALIZZATI CUSTOM SHAPE PRODUCTS PRODUCTOS INYECTADOS PERSONALIZADOS PRODUITS MOULÉS PERSONNALISÉS FORMTEIL-SONDERANFERTIGUNGEN |
| 14 | LASTRE IN STOCK SHEETS AVAILABLE IN STOCK PLACAS DISPONIBLES EN STOCK PLAQUES DISPONIBLES EN STOCK AUF LAGER VERFÜGBARE PLATTEN | 80 | SISTEMA INCOLLAGGIO ADHESIVES FOR ACRYLIC STONE SHEETS AND SHAPES COLAS POR PIEDRA ACRILICA Y PRODUCTOS INYECTADOS ADHÉSIFS POUR PIERRE ACRYLIQUE ET PRODUITS MOULÉS KLEBER FÜR ACRYLSTEIN UND FORMTEILE |
| 15 | DIMENSIONI PERSONALIZZATE CUSTOM SIZES DIMENSIONES PERSONALIZADAS DIMENSIONS PERSONNALISÉES SONDERANFERTIGUNGEN | 82 | MACCHINARI PER TERMOFORMATURA THERMOFORMING MACHINERY EQUIPO PARA TERMOCONFORMAR ÉQUIPEMENT DE THERMOFORMAGE TIEFZIEHMASCHINEN |
| 16 | COLORI COLOURS COLORES COULEURS FARBEN | 84 | ACCESSORI CUCINA KITCHEN ACCESSORIES ACCESORIOS POR COCINA ACCESSOIRES POUR CUISINE KÜCHENZUBEHÖRE |
| 17 | COLORI VENATI VEINED COLOURS COLORES VETEADOS COULEURS MARBRÉES MARMORIERT FARBEN | 85 | ACCESSORI CUCINA E PROFESSIONALI KITCHEN AND PROFESSIONAL ACCESSORIES ACCESORIOS DE COCINA Y PROFESIONALES ACCESSOIRES POUR LA CUISINE ET PROFESSIONNELS KÜCHE UND PROFESSIONELLES ZUBEHÖR |
| 18 | LASTRE CLASSIC WHITE CLASSIC WHITE SHEETS PLANCHAS CLASSIC WHITE PLAQUES EN CLASSIC WHITE CLASSIC WHITE PLATTEN | 86 | ACCESSORI BAGNO BATHROOM ACCESSORIES ACCESORIOS POR BAÑO ACCESSOIRES POUR SALLE DE BAIN BADEZIMMER ZUBEHÖRE |
| 19 | 610MM | 87 | ACCESSORI VASCHE DA BAGNO BATHTUBS ACCESSORIES ACCESORIOS POR BAÑERA ACCESSOIRES POUR BAGNOIRES BADEWANNEN ZUBEHÖRE |
| 20 | 760MM | 88 | USO E MANUTENZIONE USE AND CARE CONSEJOS DE MANTENIMIENTO CONSEILS D'ENTRETIEN PFLEGETIPPS |
| 21 | 930MM | | |
| 22 | 1050MM | | |
| 23 | 1220MM | | |
| 24 | 1350MM | | |
| 25 | 1520MM | | |
| 26 | LASTRE COLORATE COLORED SHEETS PLACAS COLORADA PLAQUES COLORÉES FARBIGE PLATTEN | | |
| 27 | COLORI PERSONALIZZATI CUSTOM COLOURS COLORES PERSONALIZADOS COULEURS PERSONNALISÉES SONDERFARBEN | | |
| 28 | 760MM | | |
| 29 | 930 - 1350MM | | |
| 30 | VENUS COLOURS | | |
| 31 | MEDICAL COLOURS | | |



EUROCLASS: B-s1-d0

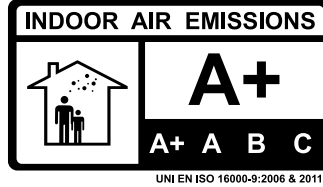

www.bimobject.com/it/bts

BTS S.p.A.

Via Repubblica 6

I - 22075 Lurate Caccivio (CO)

tel: +39.031.391007

fax: +39.031.4950331

e-mail: info@betacryl.com

web: www.betacryl.com